

# 2-Phase Hybrid Stepping Motor

**1.8°**

# KH39 series

**HIGH TORQUE, LOW VIBRATION AND LOW NOISE**

## STANDARD SPECIFICATIONS

MODEL	UNIT	KH39EM2	
		-801	-851
SHAFT	————	SINGLE	
DRIVE METHOD	————	UNI-POLAR	BI-POLAR
NUMBER OF PHASES	————	2	2
STEP ANGLE	deg./step	1.8	1.8
VOLTAGE	V	5.6	3.6
CURRENT	A/PHASE	0.4	0.6
RESISTANCE	Ω/PHASE	14.0	6.0
INDUCTANCE	mH/PHASE	6.4	5.5
HOLDING TORQUE	mN·m	59	78
	oz·in	8.3	11
DETENT TORQUE	mN·m	7.8	7.8
	oz·in	1.1	1.1
ROTOR INERTIA	g·cm <sup>2</sup>	14	14
	oz·in <sup>2</sup>	0.08	0.08
WEIGHT	g	110	110
	lb	0.24	0.24
INSULATION CLASS	————	E EQUIVALENT (120°C 248° F) (UL VALUE : CLASS B-130°C)	
INSULATION RESISTANCE	————	500VDC 100MΩmin.	
DIELECTRIC STRENGTH	————	500VAC 50HZ 1min.	
OPERATING TEMP.RANGE	°C	0 to 50	
ALLOWABLE TEMP.RISE	K	70	

## DIMENSIONS unit = mm (inch)

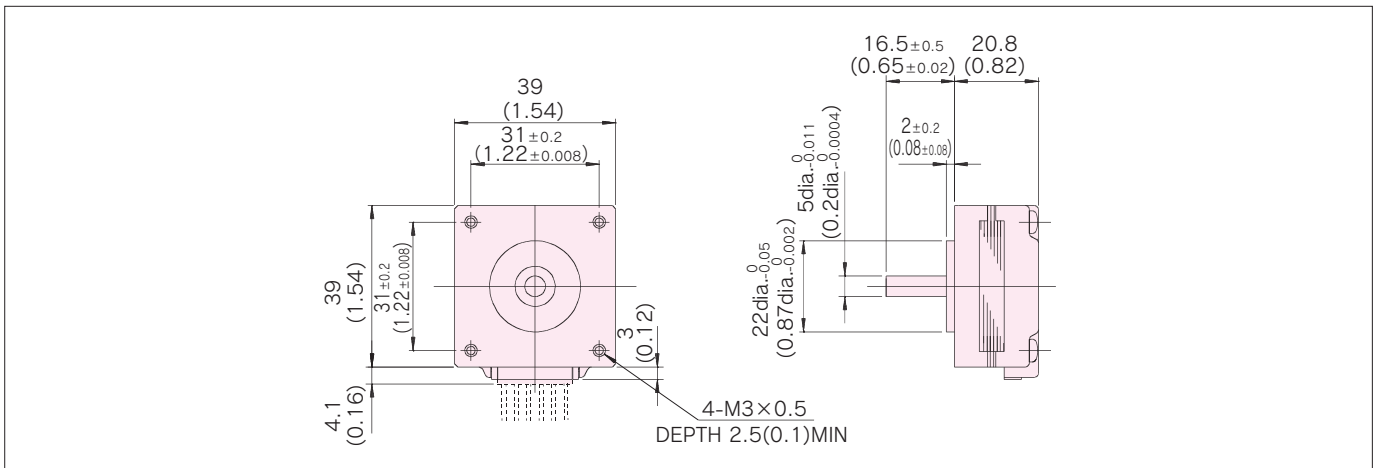



## Features

1. High torque  
Output is 1.3 times as high as conventional products.
2. Low noise -7dB(A) quieter than conventional products.

### ■ TORQUE CHARACTERISTICS VS PULSE RATE

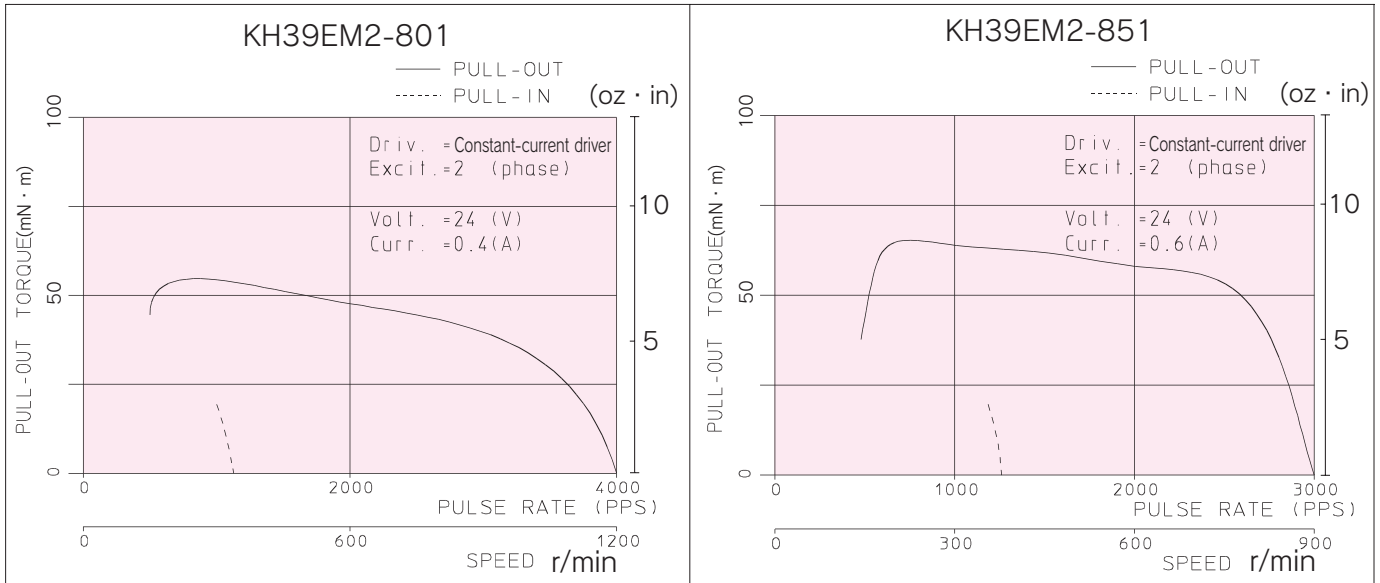

### ■ CONNECTION DIAGRAMS

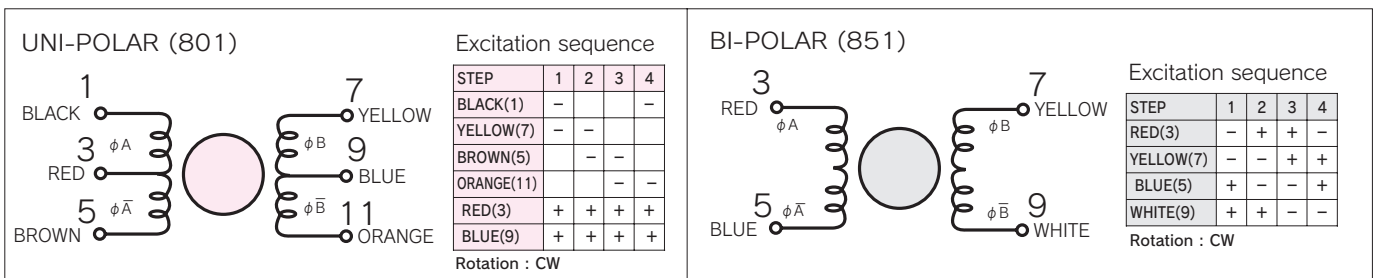

### ■ CONNECTION CABLE TO MOTOR unit=mm (inch)

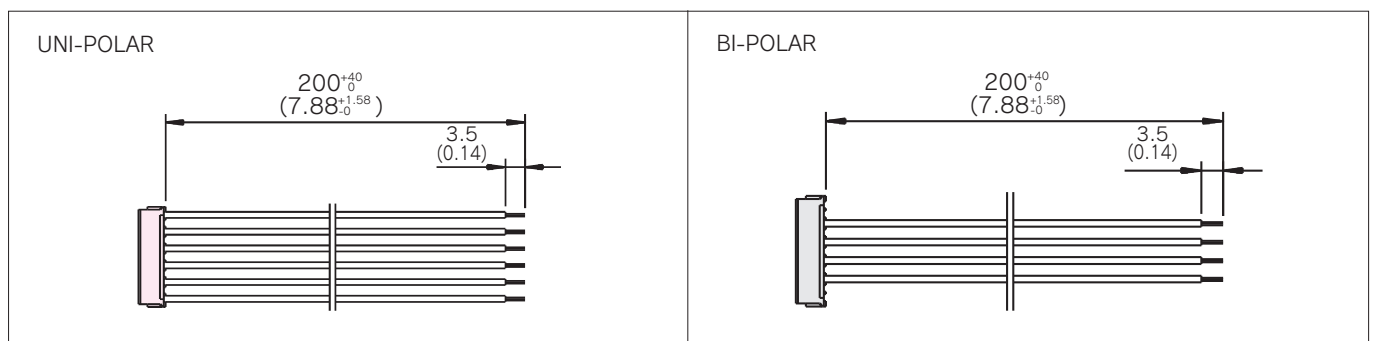

# 2-Phase Hybrid Stepping Motor

**1.8°**

# KH39 series

**HIGH TORQUE, LOW VIBRATION AND LOW NOISE**

## STANDARD SPECIFICATIONS

MODEL	UNIT	KH39FM2	
		-801	-851
DRIVE METHOD	————	UNI-POLAR	BI-POLAR
NUMBER OF PHASES	————	2	2
STEP ANGLE	deg./step	1.8	1.8
VOLTAGE	V	6.3	4
CURRENT	A/PHASE	0.42	0.67
RESISTANCE	Ω/PHASE	15.0	6.0
INDUCTANCE	mH/PHASE	8.5	6.8
HOLDING TORQUE	mN·m	88	118
	oz · in	13	17
DETENT TORQUE	mN·m	9.8	9.8
	oz · in	1.4	1.4
ROTOR INERTIA	g · cm <sup>2</sup>	19	19
	oz · in <sup>2</sup>	0.10	0.10
WEIGHT	g	160	160
	lb	0.35	0.35
INSULATION CLASS	————	E EQUIVALENT (120°C 248° F) (UL VALUE : CLASS B-130°C)	
INSULATION RESISTANCE	————	500VDC 100MΩmin.	
DIELECTRIC STRENGTH	————	500VAC 50HZ 1min.	
OPERATING TEMP.RANGE	℃	0 to 50	
ALLOWABLE TEMP.RISE	K	70	

## DIMENSIONS unit = mm (inch)

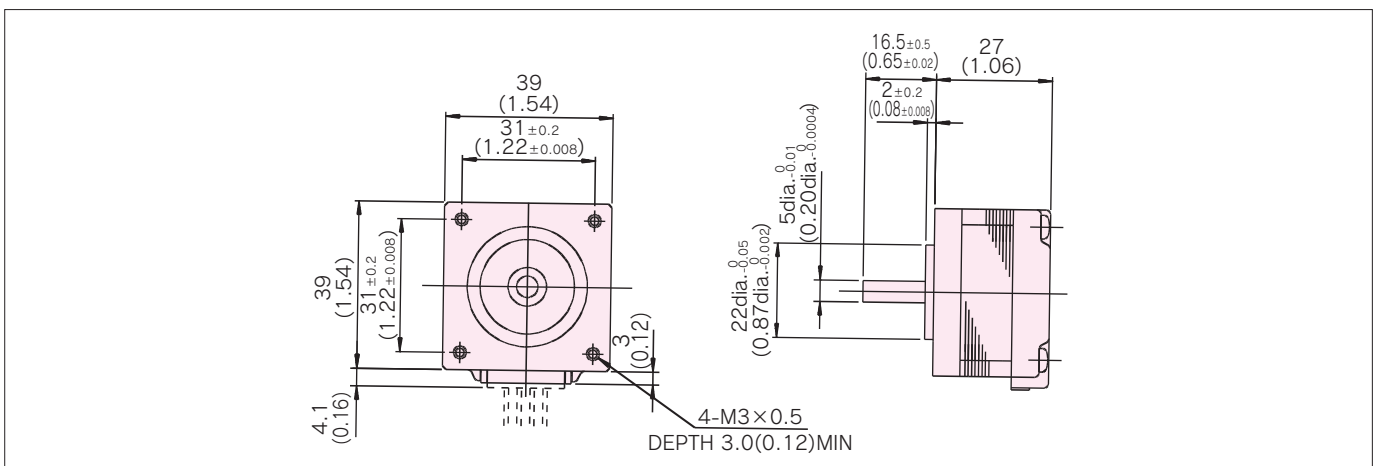



## Features

1. High torque  
Output is 1.3 times as high as conventional products.
2. Low noise -7dB(A) quieter than conventional products.

### ■ TORQUE CHARACTERISTICS vs. PULSE RATE

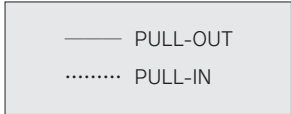
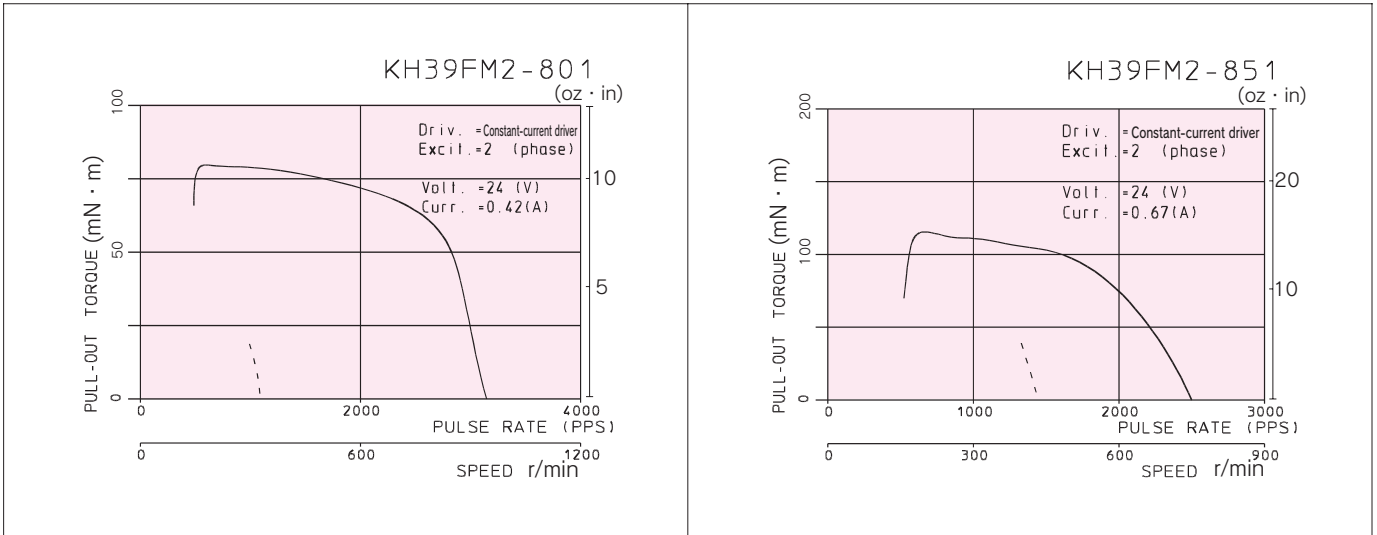

### ■ CONNECTION DIAGRAMS

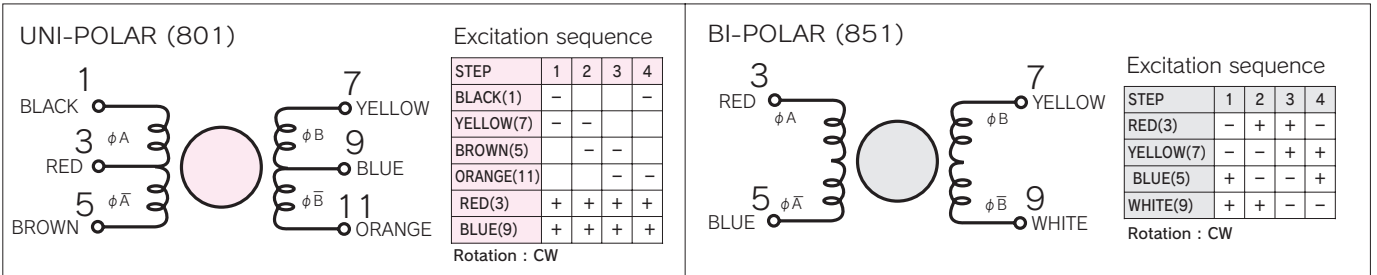

### ■ CONNECTION CABLE TO MOTOR unit = mm (inch)

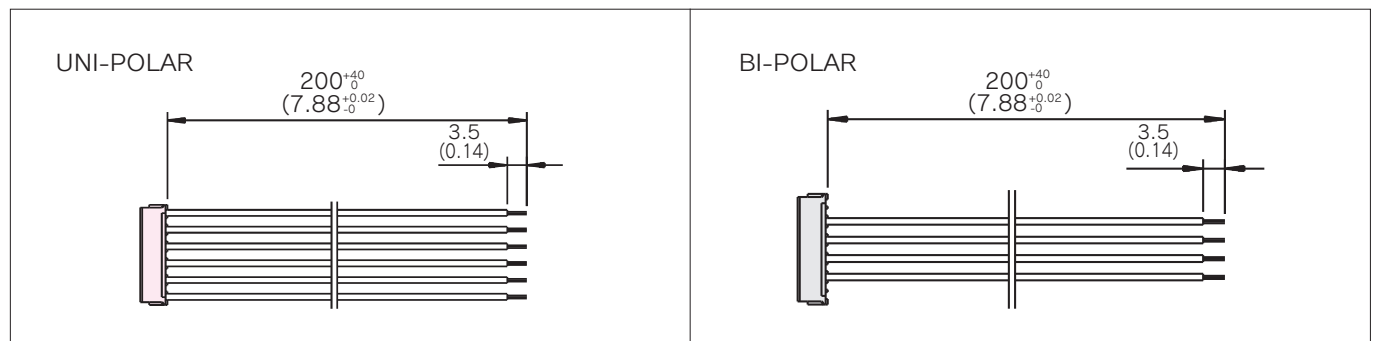

# 2-Phase Hybrid Stepping Motor

**1.8°**

# KH39 series

**HIGH TORQUE, LOW VIBRATION AND LOW NOISE**

## STANDARD SPECIFICATIONS

MODEL	UNIT	KH39GM2	
		-801	-851
DRIVE METHOD	————	UNI-POLAR	BI-POLAR
NUMBER OF PHASES	————	2	2
STEP ANGLE	deg./step	1.8	1.8
VOLTAGE	V	6.4	4.6
CURRENT	A/PHASE	0.47	0.65
RESISTANCE	Ω/PHASE	13.6	7.0
INDUCTANCE	mH/PHASE	9.8	9.8
HOLDING TORQUE	mN·m	127	157
	oz · in	18	22
DETENT TORQUE	mN·m	11.8	11.8
	oz · in	1.7	1.7
ROTOR INERTIA	g · cm <sup>2</sup>	27	27
	oz · in <sup>2</sup>	0.15	0.15
WEIGHT	g	240	240
	lb	0.53	0.53
INSULATION CLASS	————	E EQUIVALENT (120°C 248° F) (UL VALUE : CLASS B-130°C)	
INSULATION RESISTANCE	————	500VDC 100MΩmin.	
DIELECTRIC STRENGTH	————	500VAC 50HZ 1min.	
OPERATING TEMP.RANGE	℃	0 to 50	
ALLOWABLE TEMP.RISE	K	70	

## DIMENSIONS unit = mm (inch)

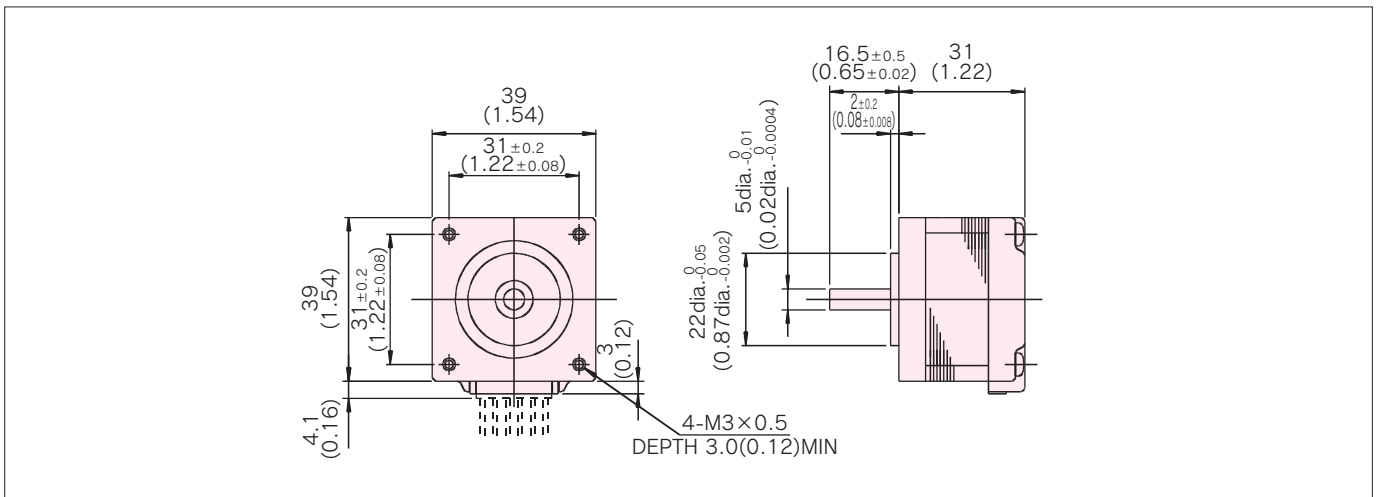



## Features

1. High torque  
Output is 1.3 times as high as conventional products.
2. Low noise -7dB(A) quieter than conventional products.

### ■ TORQUE CHARACTERISTICS vs. PULSE RATE

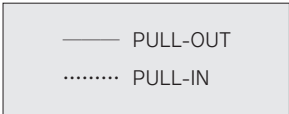
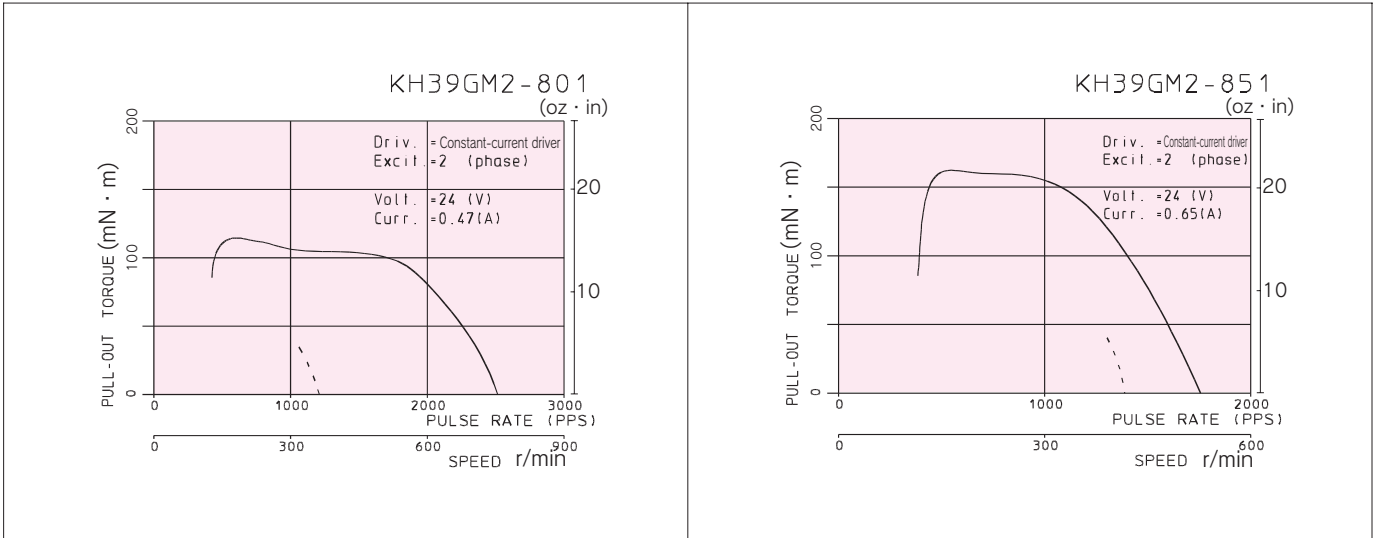

### ■ CONNECTION DIAGRAMS

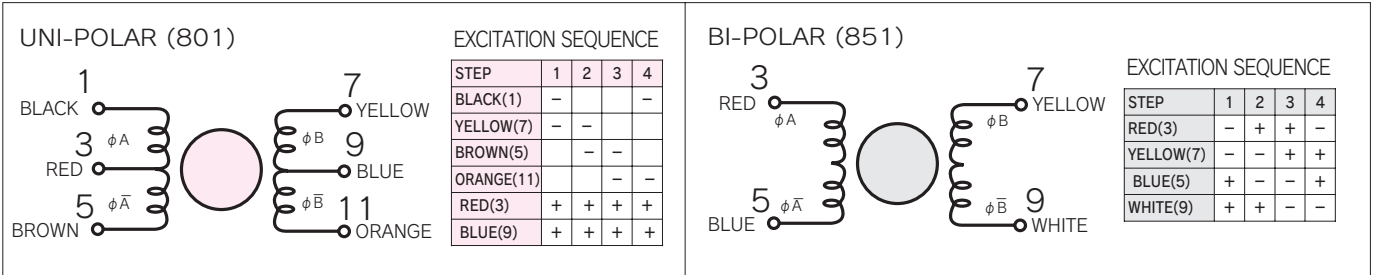

### ■ CONNECTION CABLE TO MOTOR unit = mm (inch)

