

Standard gear drives for small and medium
volume production based on the modular system

Planetary Gears IMS.baseline



Our Planetary gears catalogue and what you'll find in it

The IMS.baseline catalogue has two fold-out pages with additional information to the single planetary gears - so you have all the relevant information at a glance.



Please refer to the fold-out page (page 11) on the left, technical data overview.

For information about the single planetary gears, please refer to the product pages (from page 12):

- Gear dimensions
- Parameter
- Reduction ratios
- Dimensions motor flange
- etc.

Please refer to the fold-out page (page 40) on the right, for specifications regarding the motor attachment.

Page	BASIC INFORMATION
2	Philosophy
3	Always the optimum - Modification options and quantity structures
4	Interaction - Overview planetary gears
6	The modular system and its possibilities
8	First steps for planetary gear selection
10	Summary of torque ranges
11	Technical data overview

OUR TYPE SERIES

metal (PM), plastic (PK) and Low Noise (LN)

12	Ø 22 mm	PK	0.2 - 0.6 Nm
14	Ø 32 mm	PK	0.4 - 2.0 Nm
16	Ø 42 mm	PK	0.8 - 4.0 Nm
18	Ø 52 mm	PK	2.0 - 10.0 Nm
20	Ø 22 mm	PM	0.6 - 0.8 Nm
22	Ø 32 mm	PM/LN	0.8 - 4.5 Nm
24	Ø 42 mm	PM/LN	3.0 - 15.0 Nm
26	Ø 52 mm	PM/LN	4.0 - 25.0 Nm
28	Ø 62 mm	PM/LN	8.0 - 50.0 Nm
30	Ø 72 mm	PM/LN	14.0 - 84.0 Nm
32	Ø 81 mm	PM/LN	20.0 - 120.0 Nm
34	Ø 105 mm	PM/LN	35.0 - 195.0 Nm
36	Ø 120 mm	PM	50.0 - 300.0 Nm

38	Examples of configuration
40	Specifications for motor attachment



This catalogue and its limits. Our modular system provides more than 10,000 variants. Because of this immense variety, we are only able to introduce some selected gears in this catalogue. If the planetary gear you are looking for should not be mentioned, please contact us. We are happy to help.



Always the optimum

	IMS.baseline	IMS.techline	IMS.SDline
MODIFICATION OPTIONS	-/✓		
Motor-/output end	✓	✓	✓
Geardrive diameter	—	✓	✓
Material mix	—	✓	✓
Reduction ratio	—	✓	✓
Geometry of toothed parts	—	—	✓
Material of toothed parts	—	—	✓
Tooth shape	—	—	—

Philosophy

Planetary Gears from IMS.baseline are the solution for **small and medium production runs** as well as **samples**. This product line is characterized by **tremendous diversity** and **fast availability**.

IMS.baseline offers a broad range of different diameters, materials and reduction ratios as well as adapter options to suit different motor and output configurations. In excess of 1,800 variants provide solutions for virtually all problem scenarios. The high level of value added specific to IMS Gear products assures fast delivery capability and an optimum price-performance ratio.

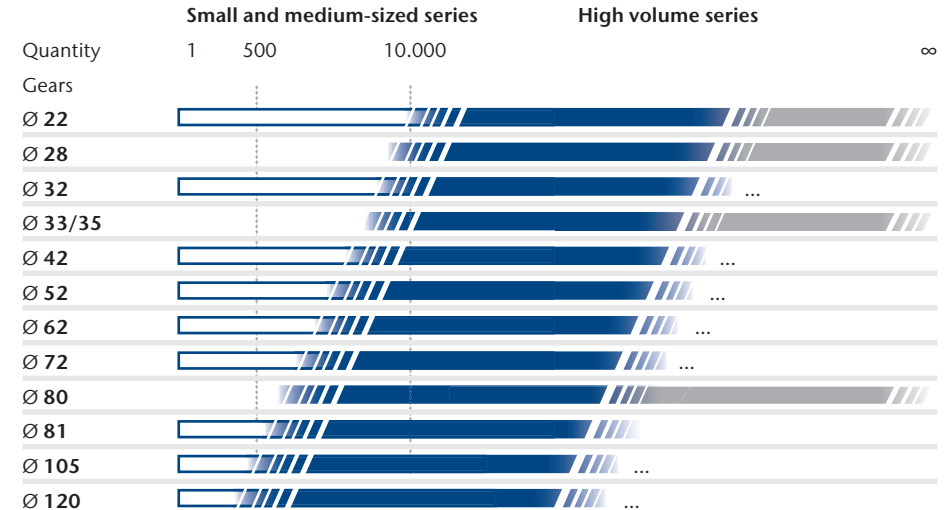

 **All figures are approximate values.** Variations are possible and may arise for example due to non-standardized inspection and measurement methods. For more detailed information, please contact us directly. The company always reserves the right to make technical modifications. For current status, please consult our website www.ims-gear.com

Interaction

Fast availability and highly adaptable

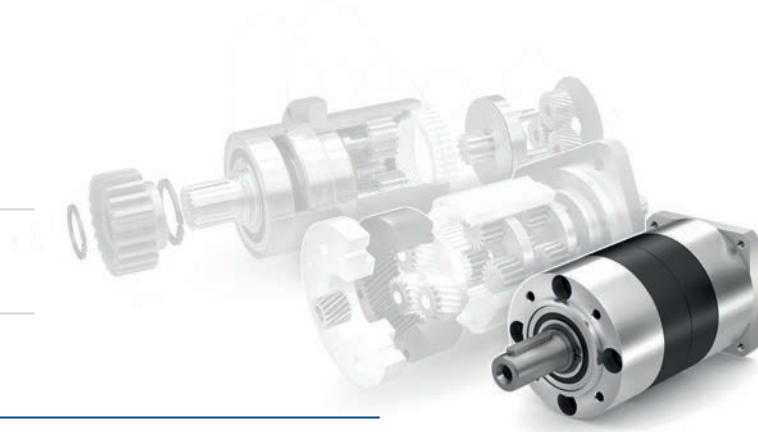

IMS.SDline

IMS.techline

IMS.baseline

PLANETARY GEARS FROM IMS.BASELINE constitute a fast and adaptable solution from a modular design concept, beginning with validation of the first idea all the way through to principle tests and function samples.

The results can then be implemented in a short production run or a specification document or the creation of near-production sample components.

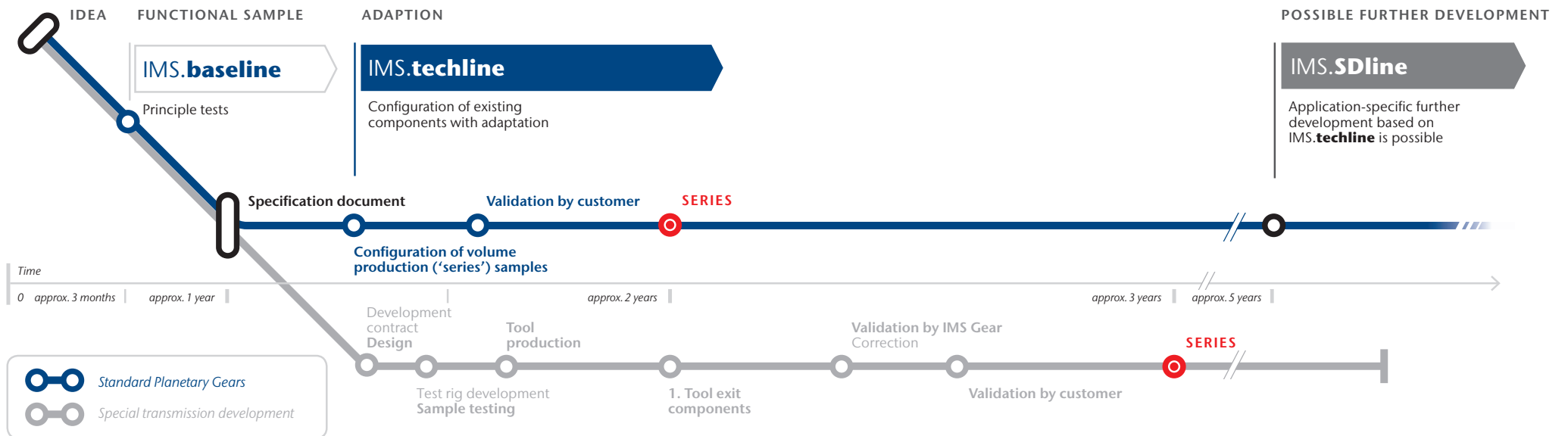

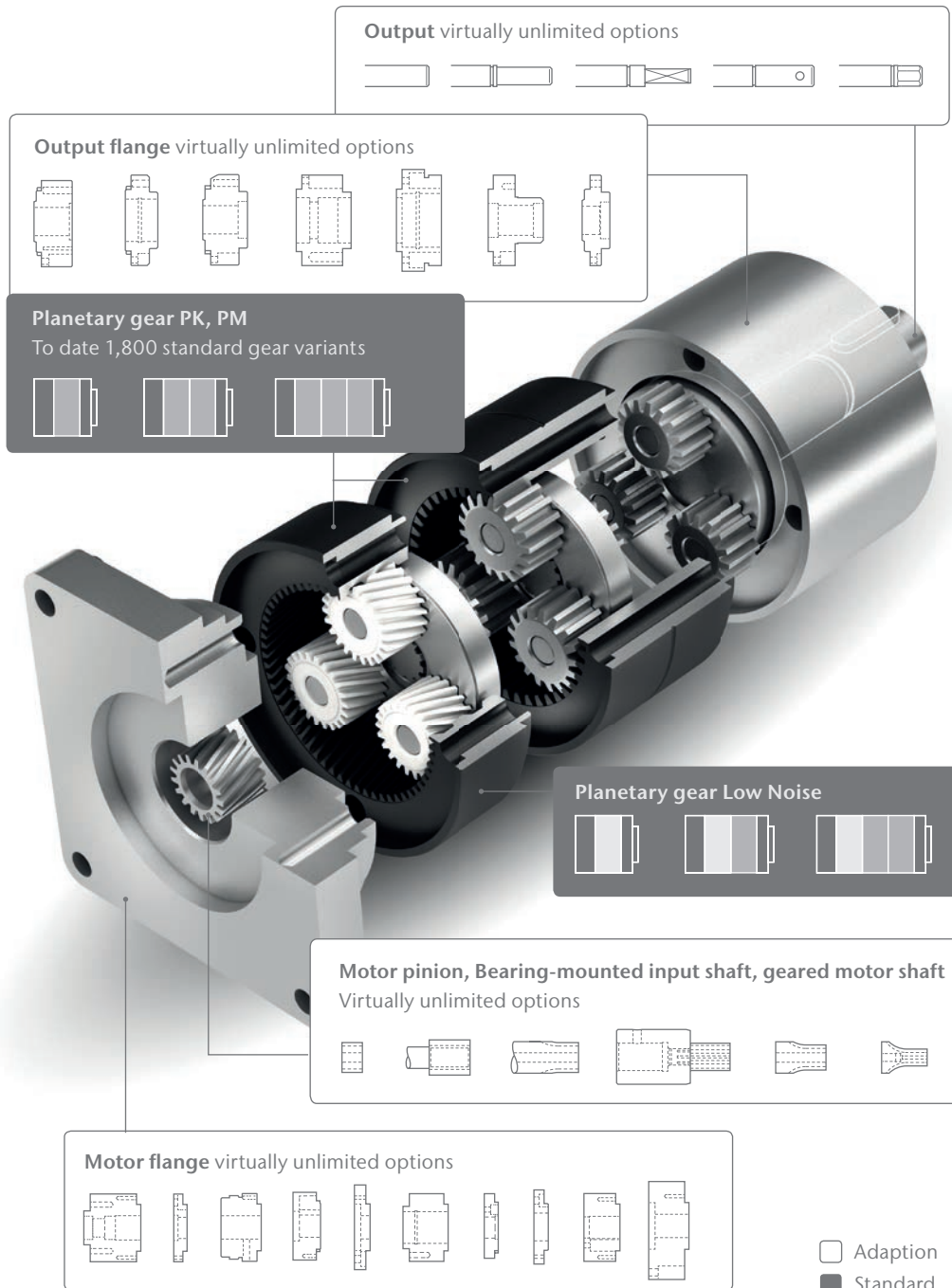

The modular system and its options

MOTOR PINION ADAPTION

Our planetary gears are designed for connecting any current type of motor, using three different modes: with different motor pinions in various designs or by bearing-mounted input shaft. With appropriate quantities and after consultations with the motor manufacturer, the motor shaft can also be intermeshed directly. With an adapted motor mounting plate, the motor can then be connected to the annular wheel without any additional motor flange, allowing shorter and more cost-effective gearing assemblies.

MOTOR FLANGE ADAPTION

Flanges are available in plastic, die cast zinc or aluminium, adapted individually depending on the requirements. For larger quantities you can also obtain toolspecific special flanges, e.g. made of plastic or die cast zinc. Type series PM 52 to PM 120 are also available with standard DIN 42948 flanges.

PLANETARY GEARS LOW NOISE STANDARD

The Low Noise modules for the first stage feature a well-tuned combination of module, number of teeth, helical angle, gearing width and choice of material, guaranteeing ultimate smooth running and high torque stability. The external dimensions and reductions, identical to those of the straight-toothed gears and differing only in microns, allow easy replacement

in most cases.

PLANETARY GEARS PK, PM STANDARD

Nine different diameters with as many as three (even four on request) gear stages and a wide variety of reduction ratios ranging from 3.7:1 to 601:1 are available in plastic, metal or material mix versions with output torques ranging from 0.2 to 300 Nm. Although this results in an immense variety of options, we describe our planetary gears (PLGs) as standard gears, which can be manufactured in high-volume production and therefore cost-effective.

OUTPUT FLANGE ADAPTION

The output flange includes the bearing. Sintered metal bearings or ball bearings can be selected to match the operating requirements. Gearboxes with two RS seals in the ball bearing of the output shaft are protection class IP 53, whereas with two Z cover disks they are protection class IP 42. Sintered metal versions are protection class IP 00. Higher protection classes can be implemented by applying specific seals.

OUTPUT ADAPTION

The planet carrier of the last stage and the output shaft are manufactured in one piece without any additional assembly effort. Depending on the machine to be driven, the output shaft can be designed in any customer specific layout.

Please refer the brochure plg.technology for additional information.

First steps for planetary gear selection

The T_{AB} **output torque** is one of the first important variables when selecting the most suitable PLG.

The maximum **output torque** T_{AB} is calculated from the **Nominal output torque** T_N multiplied with the **operating factor** C_B .

$$T_{AB} = T_N * C_B$$

C_B is a factor which addresses the different working conditions of a PLG and needs to be selected by you to suit your individual application. All figures in this catalogue refer to $C_B = 1$, this means: constant direction of rotation, no shocks, daily operating time of 3 hours. (Details C_B -values refer to page 9.)

For PM gears the 1.5 times T_{AB} is temporary possible, but needs to be checked application-specific.

The **Nominal output torque** T_N is calculated from the **Motor torque** T_M multiplied with the desired reduction ratio i

- 1-stage** 4:1 bis 13:1
- 2-stage** 14:1 bis 89:1
- 3-stage** 51:1 bis 601:1

and the respective **gear efficiency** η .

For the available **reduction ratios** i and details of the **gear efficiency** η , please refer to the appropriate type series in this catalogue.

$$T_N = T_M * i * \eta$$

- i = Reduction ratio
- T_{AB} = Output torque
- T_N = Nominal output torque
- T_M = Motor torque
- η = Gear efficiency
- C_B = Operating factor

Determining the operating factor C_B

Direction of rotation	Load (shocks)	Daily operating time		
		3h	8h	24h
constant	none	$C_B = 1.0$	$C_B = 1.1$	$C_B = 1.3$
	medium	$C_B = 1.2$	$C_B = 1.3$	$C_B = 1.5$
	strong	$C_B = 1.4$	$C_B = 1.5$	$C_B = 1.8$
alternating	none	$C_B = 1.3$	$C_B = 1.4$	$C_B = 1.6$
	medium	$C_B = 1.6$	$C_B = 1.7$	$C_B = 1.9$
	strong	$C_B = 1.9$	$C_B = 2.0$	$C_B = 2.2$

Summary of torque ranges

The graphic below is intended to support you getting a first orientation in selecting a planetary gear

OUTPUT TORQUE T_{AB} IN Nm

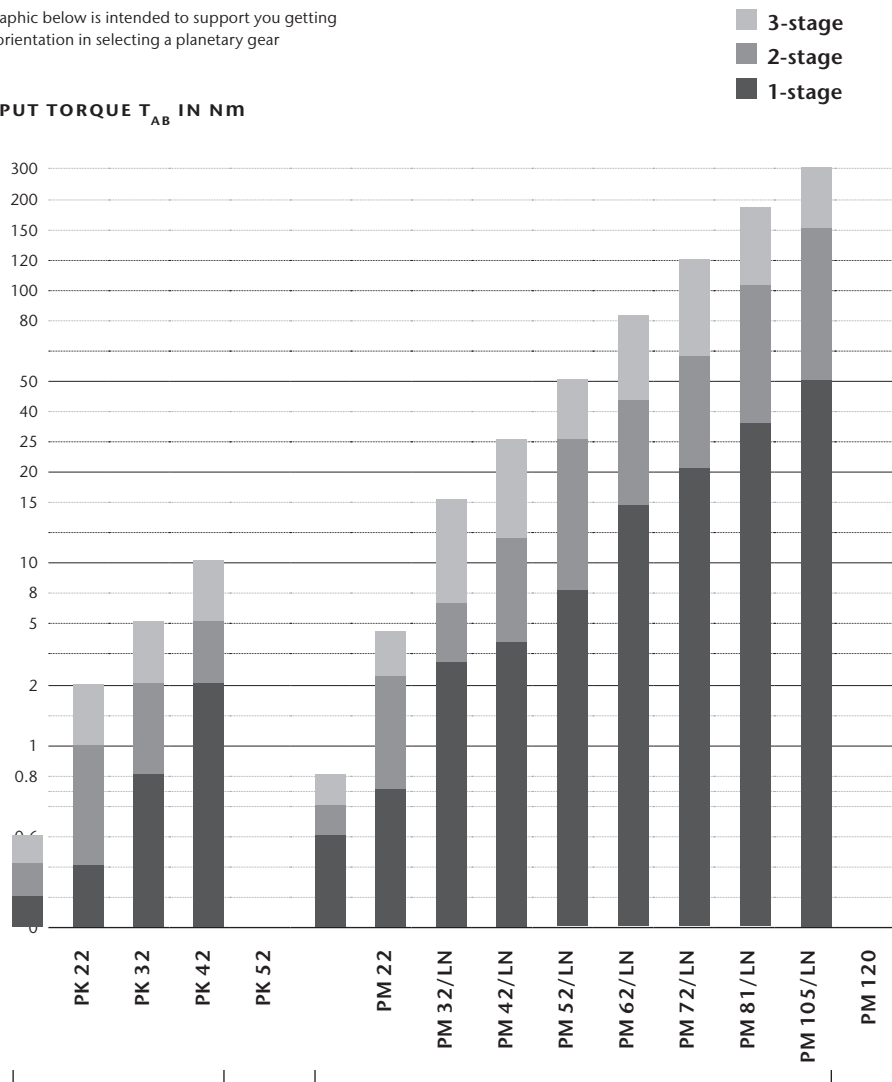

PK: PLANETARY GEAR PLASTIC

PM: PLANETARY GEAR METAL

Technical data overview

For details regarding the type series please refer to the product pages.

	Permitted output torque* (Operating factor $C_B = 1.0$)			Recommended input speed	Radial loading (10 mm from flange)*	Max. axial loading*
	1-stage	2-stage	3-stage			
PK 22	0.2 Nm	0.4 Nm	0.6 Nm	6,000 U/min	15 - 45 N	30 N
PM 22	0.6 Nm	0.7 Nm	0.8 Nm	6,000 U/min	25 - 50 N	10 - 15 N
PK 32	0.4 Nm	1.0 Nm	2.0 Nm	3,000 U/min	15 - 45 N	5 - 15 N
PM 32/LN	0.75 Nm	2.25 Nm	4.5 Nm	3,000 U/min	40 - 100 N	10 - 30 N
PK 42	0.8 Nm	2.0 Nm	4.0 Nm	3,000 U/min	15 - 45 N	5 - 30 N
PM 42/LN	3.0 Nm	7.5 Nm	15.0 Nm	3,000 U/min	160 - 300 N	50 - 110 N
PK 52	2.0 Nm	5.0 Nm	10.0 Nm	3,000 U/min	200 - 450 N	60 - 150 N
PM 52/LN	4.0 Nm	12.0 Nm	25.0 Nm	3,000 U/min	200 - 450 N	60 - 150 N
PM 62/LN	8.0 Nm	25.0 Nm	50.0 Nm	3,000 U/min	240 - 520 N	70 - 150 N
PM 72/LN	14.0 Nm	42.0 Nm	84.0 Nm	3,000 U/min	320 - 760 N	70 - 160 N
PM 81/LN	20.0 Nm	60.0 Nm	120.0 Nm	3,000 U/min	400 - 1,000 N	80 - 200 N
PM 105/LN	35.0 Nm	105.0 Nm	195.0 Nm	3,000 U/min	600 - 1,500 N	120 - 300 N
PM 120	50.0 Nm	150.0 Nm	300.0 Nm	3,000 U/min	600 - 1,500 N	120 - 300 N

* Greater performance capability regarding axial or radial load as well as output torque may be available and feasible on request.

PK: Planetary Gear plastic PM: Planetary Gear metal LN: Low Noise

$C_B = 1.0$: constant direction of rotation, no shock load, daily operating time of 3 hours

Diameter: equates to designation, e.g. PK 22 with $\varnothing 22$

Operating temperature: On PK Gears -15°C to $+65^\circ\text{C}$; with PM/LN Gears -30°C to $+120^\circ\text{C}$

Type of bearing on output end: Sinter bearings on PK Gears and ball bearings on PM/LN Gears;

PK 52 is an exception, equipped with ball bearing

Please refer the brochure plg.technology for additional information.

PK 22 $\varnothing 22$ mm, plastic

Parameter	1-stage	2-stage	3-stage
Perm. output torque Appl. factor ($C_B = 1.0$)	0.2 Nm	0.4 Nm	0.6 Nm
Gearbox efficiency, approx.	0.80	0.75	0.70
Max. backlash	1.50 °DEG	2.00 °DEG	2.50 °DEG
Recommended initial speed	6,000 U/min	6,000 U/min	6,000 U/min
Min. Operating temperature	-15 °C	-15 °C	-15 °C
Max. Operating temperature	+65 °C	+65 °C	+65 °C

Current reduction ratios i rounded

1-stage	2-stage	3-stage
4:1 (3.71)	14:1 (13.73)	51:1 (50.89)
4:1 (4.29)	16:1 (15.88)	59:1 (58.86)
5:1 (5.18)	18:1 (18.37)	68:1 (68.07)
7:1 (6.75)	19:1 (19.20)	71:1 (71.16)
	22:1 (22.21)	79:1 (78.72)
	25:1 (25.01)	93:1 (92.70)
	27:1 (26.85)	95:1 (95.18)
	29:1 (28.93)	100:1 (99.51)
	35:1 (34.98)	107:1 (107.21)
	46:1 (45.56)	115:1 (115.08)
		124:1 (123.98)
		130:1 (129.62)
		139:1 (139.14)
		150:1 (149.90)
		169:1 (168.85)
		181:1 (181.25)
		195:1 (195.27)
		236:1 (236.10)
		308:1 (307.55)

Output side with sintered metal bearing	1-stage	2-stage	3-stage
Max. load, radial (10mm from flange)	15 N	30 N	45 N
Max. load, axial	30 N	30 N	30 N
Max. perm.fitting pressure	150 N	150 N	150 N
Weight approx.	33 g	42 g	50 g

Gearbox length in mm	1-stage	2-stage	3-stage
Length l*	24.25 ± 0.5	32.4 ± 0.5	40.6 ± 0.5

*The minimum length is only possible with an optimal attachment to the motor, the actual length we like to determine for you.

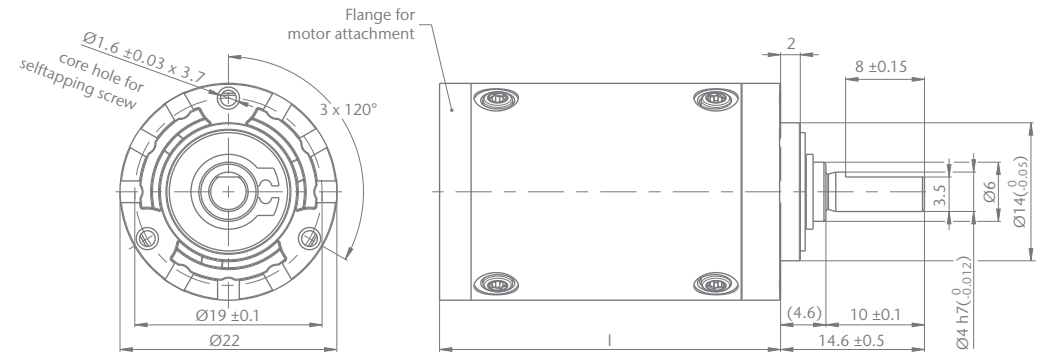

All figures are approximate values.
 Variations are possible and may arise for example due to non-standardized inspection and measurement methods. For more detailed information, please contact us directly. The company always reserves the right to make technical modifications. For current status, please consult www.imsgear.com

PK 32 Ø 32 mm, plastic

Parameter	1-stage	2-stage	3-stage
Perm. output torque Appl. factor ($C_B = 1.0$)	0.4 Nm	1.0 Nm	2.0 Nm
Gearbox efficiency. approx.	0.75	0.70	0.65
Max. backlash	1.90 °DEG	1.95 °DEG	2.00 °DEG
Recommended initial speed	3,000 U/min	3,000 U/min	3,000 U/min
Min. Operating temperature	-15 °C	-15 °C	-15 °C
Max. Operating temperature	+65 °C	+65 °C	+65 °C

Current reduction ratios i rounded

1-stage	2-stage	3-stage
4:1 (3.71)	14:1 (13.73)	51:1 (50.89)
4:1 (4.29)	16:1 (15.88)	59:1 (58.86)
5:1 (5.18)	18:1 (18.37)	68:1 (68.07)
7:1 (6.75)	19:1 (19.20)	71:1 (71.16)
	22:1 (22.21)	79:1 (78.72)
	25:1 (25.01)	93:1 (92.70)
	27:1 (26.85)	95:1 (95.18)
	29:1 (28.93)	100:1 (99.51)
	35:1 (34.98)	107:1 (107.21)
	46:1 (45.56)	115:1 (115.08)
		124:1 (123.98)
		130:1 (129.62)
		139:1 (139.14)
		150:1 (149.90)
		169:1 (168.85)
		181:1 (181.25)
		195:1 (195.27)
		236:1 (236.10)
		308:1 (307.55)

Output side with sintered metal bearing	1-stage	2-stage	3-stage
Max. load, radial (Middle output shaft)	15 N	30 N	45 N
Max. load, axial	5 N	10 N	15 N
Max. perm.fitting pressure	150 N	150 N	150 N
Weight approx.	100 g	115 g	130 g

Gearbox length in mm	1-stage	2-stage	3-stage
Length l*	29.6 ± 0.5	39.1 ± 0.5	48.6 ± 0.5

*The minimum length is only possible with an optimal attachment to the motor, the actual length we like to determine for you.

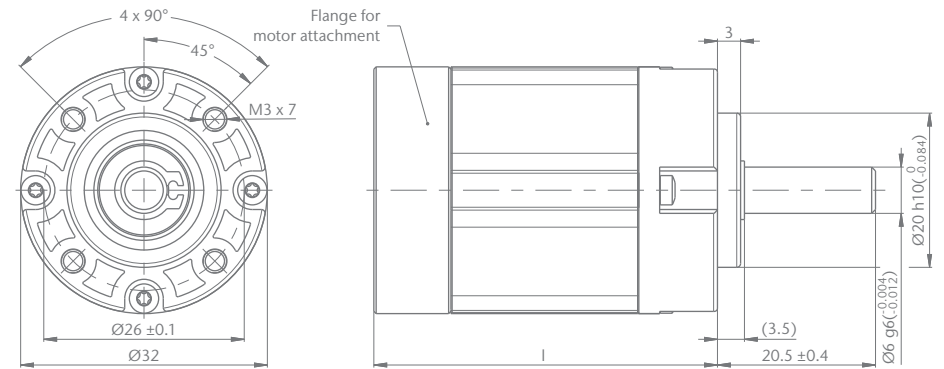

! All figures are approximate values.
 Variations are possible and may arise for example due to non-standardized inspection and measurement methods. For more detailed information, please contact us directly. The company always reserves the right to make technical modifications. For current status, please consult www.imsgear.com

PK 42 Ø 42 mm, plastic

Parameter	1-stage	2-stage	3-stage
Perm. output torque Appl. factor ($C_B = 1,0$)	0.8 Nm	2.0 Nm	4.0 Nm
Gearbox efficiency, approx.	0.80	0.75	0.70
Max. backlash	1.70 °DEG	1.75 °DEG	1.80 °DEG
Recommended initial speed	3,000 U/min	3,000 U/min	3,000 U/min
Min. Operating temperature	-15 °C	-15 °C	-15 °C
Max. Operating temperature	+65 °C	+65 °C	+65 °C

Current reduction ratios i rounded

1-stage	2-stage	3-stage
4:1 (3.71)	14:1 (13.73)	51:1 (50.89)
4:1 (4.29)	16:1 (15.88)	59:1 (58.86)
5:1 (5.18)	18:1 (18.37)	68:1 (68.07)
7:1 (6.75)	19:1 (19.20)	71:1 (71.16)
	22:1 (22.21)	79:1 (78.72)
	25:1 (25.01)	93:1 (92.70)
	27:1 (26.85)	95:1 (95.18)
	29:1 (28.93)	100:1 (99.51)
	35:1 (34.98)	107:1 (107.21)
	46:1 (45.56)	115:1 (115.08)
		124:1 (123.98)
		130:1 (129.62)
		139:1 (139.14)
		150:1 (149.90)
		169:1 (168.85)
		181:1 (181.25)
		195:1 (195.27)
		236:1 (236.10)
		308:1 (307.55)

Output side with sintered metal bearing	1-stage	2-stage	3-stage
Max. load, radial (Middle output shaft)	15 N	30 N	45 N
Max. load, axial	5 N	10 N	30 N
Max. perm.fitting pressure	150 N	150 N	150 N
Weight approx.	150 g	180 g	215 g

Gearbox length in mm	1-stage	2-stage	3-stage
Length l*	48.7	61.7	74.7

* The minimum length is only possible with an optimal attachment to the motor, the actual length we like to determine for you.

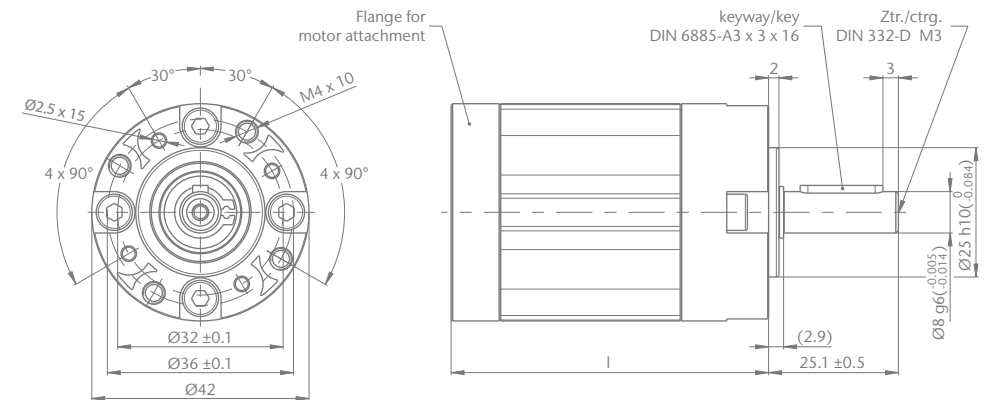

All figures are approximate values.
 Variations are possible and may arise for example due to non-standardized inspection and measurement methods. For more detailed information, please contact us directly. The company always reserves the right to make technical modifications. For current status, please consult www.imsgear.com

PK 52 $\varnothing 52$ mm, plastic

Parameter	1-stage	2-stage	3-stage
Perm. output torque Appl. factor ($C_B = 1.0$)	2.0 Nm	5.0 Nm	10.0 Nm
Gearbox efficiency. approx.	0.75	0.70	0.65
Max. backlash	1.10 °DEG	1.15 °DEG	1.20 °DEG
Recommended initial speed	3,000 U/min	3,000 U/min	3,000 U/min
Min. Operating temperature	-15 °C	-15 °C	-15 °C
Max. Operating temperature	+65 °C	+65 °C	+65 °C

Current reduction ratios i rounded

1-stage	2-stage	3-stage
4:1 (3.71)	14:1 (13.73)	51:1 (50.89)
4:1 (4.29)	16:1 (15.88)	59:1 (58.86)
5:1 (5.18)	18:1 (18.37)	68:1 (68.07)
7:1 (6.75)	19:1 (19.20)	71:1 (71.16)
	22:1 (22.21)	79:1 (78.72)
	25:1 (25.01)	93:1 (92.70)
	27:1 (26.85)	95:1 (95.18)
	29:1 (28.93)	100:1 (99.51)
	35:1 (34.98)	107:1 (107.21)
	46:1 (45.56)	115:1 (115.08)
		124:1 (123.98)
		130:1 (129.62)
		139:1 (139.14)
		150:1 (149.90)
		169:1 (168.85)
		181:1 (181.25)
		195:1 (195.27)
		236:1 (236.10)
		308:1 (307.55)

Output side with ball bearing (2RS)	1-stage	2-stage	3-stage
Max. load, radial (Middle output shaft)	200 N	320 N	450 N
Max. load, axial	60 N	100 N	150 N
Max. perm.fitting pressure	500 N	500 N	500 N
Weight approx.	335 g	395 g	460 g

Gearbox length in mm	1-stage	2-stage	3-stage
Length l*	54.8 ± 0.5	69.2 ± 0.5	83.65 ± 0.5

*The minimum length is only possible with an optimal attachment to the motor, the actual length we like to determine for you.

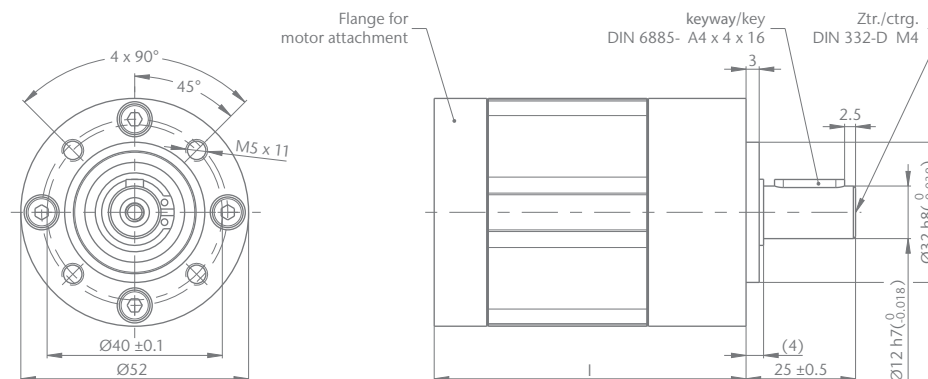

All figures are approximate values.

Variations are possible and may arise for example due to non-standardized inspection and measurement methods. For more detailed information, please contact us directly. The company always reserves the right to make technical modifications. For current status, please consult www.ims-gear.com

PM 22 $\varnothing 22$ mm, Metall

Parameter	1-stage	2-stage	3-stage
Perm. output torque Appl. factor ($C_B = 1,0$)	0.6 Nm	0.7 Nm	0.8 Nm
Gearbox efficiency, approx.	0.90	0.80	0.70
Max. backlash	1.5 °DEG	2.0 °DEG	2.5 °DEG
Recommended initial speed	6,000 U/min	6,000 U/min	6,000 U/min
Min. Operating temperature	-30 °C	-30 °C	-30 °C
Max. Operating temperature	+120 °C	+120 °C	+120 °C

Current reduction ratios i rounded

1-stage	2-stage	3-stage
4:1 (3.71)	14:1 (13.73)	51:1 (50.89)
4:1 (4.29)	16:1 (15.88)	59:1 (58.86)
5:1 (5.18)	18:1 (18.37)	68:1 (68.07)
7:1 (6.75)	19:1 (19.20)	71:1 (71.16)
	22:1 (22.21)	79:1 (78.72)
	25:1 (25.01)	93:1 (92.70)
	27:1 (26.85)	95:1 (95.18)
	29:1 (28.93)	100:1 (99.51)
	35:1 (34.98)	107:1 (107.21)
	46:1 (45.56)	115:1 (115.08)
		124:1 (123.98)
		130:1 (129.62)
		139:1 (139.14)
		150:1 (149.90)
		169:1 (168.85)
		181:1 (181.25)
		195:1 (195.27)
		236:1 (236.10)
		308:1 (307.55)

Output side with ball bearing (Z2)	1-stage	2-stage	3-stage
Max. load, radial (10 mm from flange)	25 N	35 N	50 N
Max. load, axial	10 N	15 N	15 N
Max. perm.fitting pressure	80 N	80 N	80 N
Weight approx.	43 g	59 g	75 g

Gearbox length in mm	1-stage	2-stage	3-stage
Length l*	24.25 ± 0.5	32.4 ± 0.5	40.6 ± 0.5

* The minimum length is only possible with an optimal attachment to the motor, the actual length we like to determine for you.

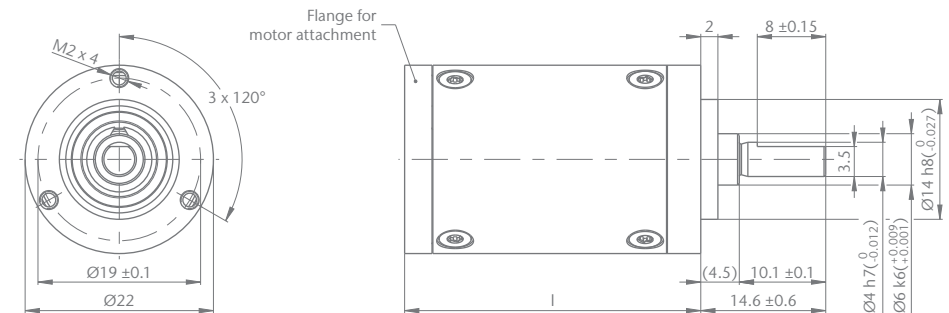

All figures are approximate values.
 Variations are possible and may arise for example due to non-standardized inspection and measurement methods. For more detailed information, please contact us directly. The company always reserves the right to make technical modifications. For current status, please consult www.imsgear.com

PM 32/LN Ø 32 mm, Metall-Low-Noise

Parameter	1-stage	2-stage	3-stage
Perm. output torque Appl. factor ($C_B = 1.0$)	0.75 Nm	2.25 Nm	4.50 Nm
Gearbox efficiency, approx.	0.80	0.75	0.70
Max. backlash	1.50 °DEG*	1.55 °DEG	1.60 °DEG
Recommended initial speed	3,000 U/min	3,000 U/min	3,000 U/min
Min. Operating temperature	-30 °C	-30 °C	-30 °C
Max. Operating temperature	+120 °C	+120 °C	+120 °C

* LN: 2,00 °DEG. For plastic PL wheels only! Impact of 1st stage for 2-4 stage versions is negligible.

Current reduction ratios i rounded (PM/LN)

1-stage	2-stage	3-stage
4:1 (3.71)	14:1 (13.73)	51:1 (50.89)
4:1 (4.29)	16:1 (15.88)	59:1 (58.86)
5:1 (5.18)	18:1 (18.37)	68:1 (68.07)
7:1 (6.75)	19:1 (19.20)	71:1 (71.16)
	22:1 (22.21)	79:1 (78.72)
	25:1 (25.01)	93:1 (92.70)
	27:1 (26.85)	95:1 (95.18)
	29:1 (28.93)	100:1 (99.51)
	35:1 (34.98)	107:1 (107.21)
	46:1 (45.56)	115:1 (115.08)
		124:1 (123.98)
		130:1 (129.62)
		139:1 (139.14)
		150:1 (149.90)
		169:1 (168.85)
		181:1 (181.25)
		195:1 (195.27)
		236:1 (236.10)
		308:1 (307.55)

Output side with ball bearing (Z2)	1-stage	2-stage	3-stage
Max. load, radial (Middle output shaft)	40 N	70 N	100 N
Max. load, axial	10 N	20 N	30 N
Max. perm.fitting pressure	120 N	120 N	120 N
Weight approx.	160 g	210 g	260 g

Gearbox length in mm	1-stage	2-stage	3-stage
Length l*	25.8 ± 0.5	35.3 ± 0.5	44.8 ± 0.5

* The minimum length is only possible with an optimal attachment to the motor, the actual length we like to determine for you.

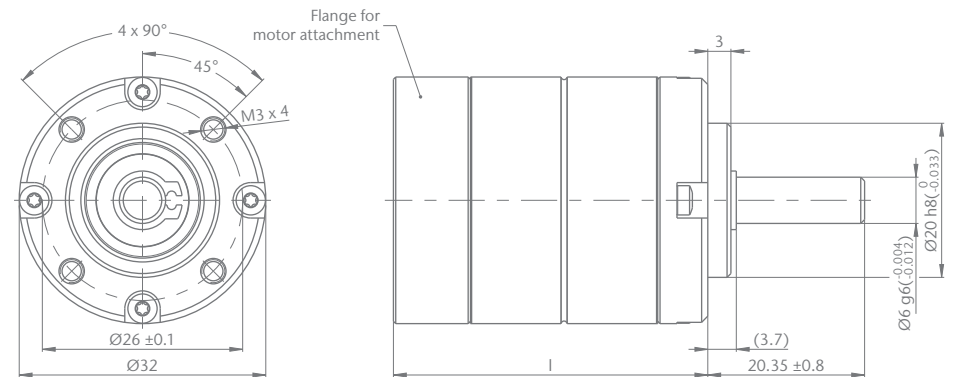

! All figures are approximate values.
 Variations are possible and may arise for example due to non-standardized inspection and measurement methods. For more detailed information, please contact us directly. The company always reserves the right to make technical modifications. For current status, please consult www.imsgear.com

PM 42/LN Ø 42 mm, Metall-Low-Noise

Parameter	1-stage	2-stage	3-stage
Perm. output torque Appl. factor ($C_B = 1.0$)	3.0 Nm	7.5 Nm	15.0 Nm
Gearbox efficiency, approx.	0.80	0.75	0.70
Max. backlash	0.90 °DEG*	0.95 °DEG	1.00 °DEG
Recommended initial speed	3,000 U/min	3,000 U/min	3,000 U/min
Min. Operating temperature	-30 °C	-30 °C	-30 °C
Max. Operating temperature	+120 °C	+120 °C	+120 °C

* LN: 1,30 °DEG. For plastic PL wheels only! Impact of 1st stage for 2-4 stage versions is negligible.

Current reduction ratios i rounded

1-stage		2-stage		3-stage	
PM	LN	PM	LN	PM	LN
4:1 (3.71)	4:1 (3.65)	14:1 (13.73)	14:1 (13.53)	51:1 (50.89)	50:1 (50.16)
4:1 (4.29)	5:1 (4.59)	16:1 (15.88)	16:1 (15.65)	59:1 (58.86)	58:1 (58.01)
5:1 (5.18)	5:1 (5.36)	18:1 (18.37)	17:1 (17.00)	68:1 (68.07)	67:1 (67.08)
7:1 (6.75)	7:1 (6.55)	19:1 (19.20)	19:1 (18.92)	71:1 (71.16)	70:1 (70.13)
	9:1 (8.63)	22:1 (22.21)	23:1 (22.96)	79:1 (78.72)	81:1 (81.11)
	*13:1 (13.20)	25:1 (25.01)	25:1 (24.65)	93:1 (92.70)	91:1 (91.36)
		27:1 (26.85)	28:1 (27.76)	95:1 (95.18)	98:1 (98.07)
		29:1 (28.93)	28:1 (28.05)	100:1 (99.51)	102:1 (101.89)
		35:1 (34.98)	34:1 (33.92)	107:1 (107.21)	106:1 (105.65)
		46:1 (45.56)	45:1 (44.69)	115:1 (115.08)	115:1 (114.77)
			58:1 (58.22)	124:1 (123.98)	123:1 (123.20)
			*68:1 (64.40)	130:1 (129.62)	128:1 (127.74)
			*89:1 (89.10)	139:1 (139.14)	137:1 (136.99)
				150:1 (149.90)	145:1 (145.36)
				169:1 (168.85)	166:1 (166.40)
				181:1 (181.25)	176:1 (175.75)
				195:1 (195.27)	192:1 (191.54)
				236:1 (236.10)	232:1 (231.59)
				308:1 (307.55)	302:1 (301.68)
					393:1 (392.98)
					*462:1 (461.70)
					*601:1 (601.43)

* not all reduction ratios available ex-stock

Output side with ball bearing (2RS)	1-stage	2-stage	3-stage
Max. load, radial (Middle output shaft)	160 N	230 N	300 N
Max. load, axial	50 N	80 N	110 N
Max. perm.fitting pressure	320 N	320 N	320 N
Weight approx.	275 g	385 g	500 g

Gearbox length in mm	1-stage	2-stage	3-stage
Length l*	49.1 ± 0.5	62.2 ± 0.5	75.3 ± 0.5

*The minimum length is only possible with an optimal attachment to the motor, the actual length we like to determine for you.

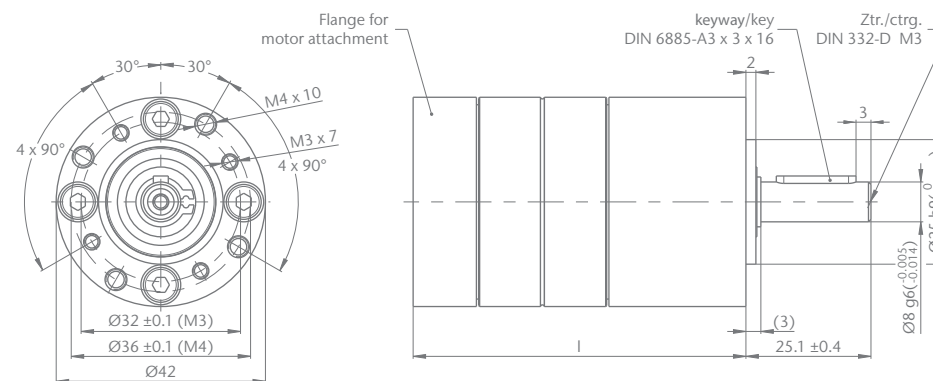

! All figures are approximate values.
 Variations are possible and may arise for example due to non-standardized inspection and measurement methods. For more detailed information, please contact us directly. The company always reserves the right to make technical modifications. For current status, please consult www.imsgear.com

PM 52/LN Ø52 mm, Metall-Low-Noise

Parameter	1-stage	2-stage	3-stage
Perm. output torque Appl. factor ($C_B = 1.0$)	4.0 Nm	12.0 Nm	25.0 Nm
Gearbox efficiency, approx.	0.80	0.75	0.70
Max. backlash	0.70 °DEG*	0.75 °DEG	0.80 °DEG
Recommended initial speed	3,000 U/min	3,000 U/min	3,000 U/min
Min. Operating temperature	-30 °C	-30 °C	-30 °C
Max. Operating temperature	+120 °C	+120 °C	+120 °C

* LN: 1,10 °DEG. For plastic PL wheels only! Impact of 1st stage for 2-4 stage versions is negligible.

Current reduction ratios i rounded

1-stage		2-stage		3-stage	
PM	LN	PM	LN	PM	LN
4:1 (3.71)	4:1 (3.65)	14:1 (13.73)	14:1 (13.53)	51:1 (50.89)	50:1 (50.16)
4:1 (4.29)	5:1 (4.59)	16:1 (15.88)	16:1 (15.65)	59:1 (58.86)	58:1 (58.01)
5:1 (5.18)	5:1 (5.36)	18:1 (18.37)	17:1 (17.00)	68:1 (68.07)	67:1 (67.08)
7:1 (6.75)	7:1 (6.55)	19:1 (19.20)	19:1 (18.92)	71:1 (71.16)	70:1 (70.13)
	9:1 (8.63)	22:1 (22.21)	23:1 (22.96)	79:1 (78.72)	81:1 (81.11)
	*13:1 (13.20)	25:1 (25.01)	25:1 (24.65)	93:1 (92.70)	91:1 (91.36)
		27:1 (26.85)	28:1 (27.76)	95:1 (95.18)	98:1 (98.07)
		29:1 (28.93)	28:1 (28.05)	100:1 (99.51)	102:1 (101.89)
		35:1 (34.98)	34:1 (33.92)	107:1 (107.21)	106:1 (105.65)
		46:1 (45.56)	45:1 (44.69)	115:1 (115.08)	115:1 (114.77)
			58:1 (58.22)	124:1 (123.98)	123:1 (123.20)
			*68:1 (64.40)	130:1 (129.62)	128:1 (127.74)
			*89:1 (89.10)	139:1 (139.14)	137:1 (136.99)
				150:1 (149.90)	145:1 (145.36)
				169:1 (168.85)	166:1 (166.40)
				181:1 (181.25)	176:1 (175.75)
				195:1 (195.27)	192:1 (191.54)
				236:1 (236.10)	232:1 (231.59)
				308:1 (307.55)	302:1 (301.68)
					393:1 (392.98)
					*462:1 (461.70)
					*601:1 (601.43)

* not all reduction ratios available ex-stock

Output side with ball bearing (2RS)	1-stage	2-stage	3-stage
Max. load, radial (Middle output shaft)	200 N	320 N	450 N
Max. load, axial	60 N	30 N	30 N
Max. perm.fitting pressure	500 N	500 N	500 N
Weight approx. with motor flange C80	0.7 kg	0.9 kg	1.1 kg

Gearbox length in mm	1-stage	2-stage	3-stage
Length l*	54.2 ± 0.5	68.35 ± 0.5	82.6 ± 0.5

*The minimum length is only possible with an optimal attachment to the motor, the actual length we like to determine for you.

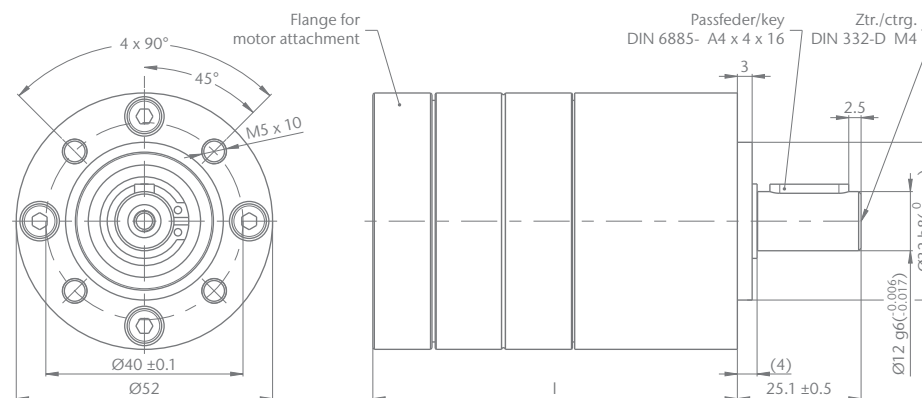

! All figures are approximate values.
 Variations are possible and may arise for example due to non-standardized inspection and measurement methods. For more detailed information, please contact us directly. The company always reserves the right to make technical modifications. For current status, please consult www.imsgear.com

PM 62/LN Ø 62 mm, Metall-Low-Noise

Parameter	1-stage	2-stage	3-stage
Perm. output torque Appl. factor ($C_B = 1.0$)	8.0 Nm	25.0 Nm	50.0 Nm
Gearbox efficiency, approx.	0.80	0.75	0.70
Max. backlash	0.65 °DEG*	0.7 °DEG	0.75 °DEG
Recommended initial speed	3,000 U/min	3,000 U/min	3,000 U/min
Min. Operating temperature	-30 °C	-30 °C	-30 °C
Max. Operating temperature	+120 °C	+120 °C	+120 °C

* LN: 0,95 °DEG. For plastic PL wheels only! Impact of 1st stage for 2-4 stage versions is negligible.

Current reduction ratios i rounded

1-stage		2-stage		3-stage	
PM	LN	PM	LN	PM	LN
4:1 (3.71)	4:1 (3.65)	14:1 (13.73)	14:1 (13.53)	51:1 (50.89)	50:1 (50.16)
4:1 (4.29)	5:1 (4.59)	16:1 (15.88)	16:1 (15.65)	59:1 (58.86)	58:1 (58.01)
5:1 (5.18)	5:1 (5.36)	18:1 (18.37)	17:1 (17.00)	68:1 (68.07)	67:1 (67.08)
7:1 (6.75)	7:1 (6.55)	19:1 (19.20)	19:1 (18.92)	71:1 (71.16)	70:1 (70.13)
	9:1 (8.63)	22:1 (22.21)	23:1 (22.96)	79:1 (78.72)	81:1 (81.11)
	*13:1 (13.20)	25:1 (25.01)	25:1 (24.65)	93:1 (92.70)	91:1 (91.36)
		27:1 (26.85)	28:1 (27.76)	95:1 (95.18)	98:1 (98.07)
		29:1 (28.93)	28:1 (28.05)	100:1 (99.51)	102:1 (101.89)
		35:1 (34.98)	34:1 (33.92)	107:1 (107.21)	106:1 (105.65)
		46:1 (45.56)	45:1 (44.69)	115:1 (115.08)	115:1 (114.77)
			58:1 (58.22)	124:1 (123.98)	123:1 (123.20)
			*68:1 (64.40)	130:1 (129.62)	128:1 (127.74)
			*89:1 (89.10)	139:1 (139.14)	137:1 (136.99)
				150:1 (149.90)	145:1 (145.36)
				169:1 (168.85)	166:1 (166.40)
				181:1 (181.25)	176:1 (175.75)
				195:1 (195.27)	192:1 (191.54)
				236:1 (236.10)	232:1 (231.59)
				308:1 (307.55)	302:1 (301.68)
					393:1 (392.98)
					*462:1 (461.70)
					*601:1 (601.43)

* not all reduction ratios available ex-stock

Output side with ball bearing (2RS)	1-stage	2-stage	3-stage
Max. load, radial (Middle output shaft)	240 N	360 N	520 N
Max. load, axial	70 N	100 N	150 N
Max. perm.fitting pressure	1,000 N	1,000 N	1,000 N
Weight approx. with motor flange C80	0.8 kg	1.2 kg	1.6 kg

Gearbox length in mm	1-stage	2-stage	3-stage
Length l*	54.6 ± 0.5	71.45 ± 0.5	88.5 ± 0.5

*The minimum length is only possible with an optimal attachment to the motor, the actual length we like to determine for you.

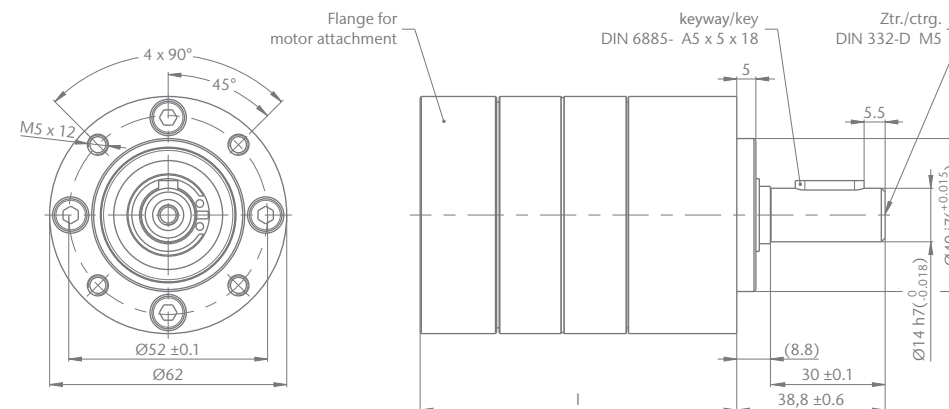

All figures are approximate values.
 Variations are possible and may arise for example due to non-standardized inspection and measurement methods. For more detailed information, please contact us directly. The company always reserves the right to make technical modifications. For current status, please consult www.imsgear.com

PM 72/LN Ø 72 mm, Metall-Low-Noise

Parameter	1-stage	2-stage	3-stage
Perm. output torque Appl. factor ($C_B = 1.0$)	14.0 Nm	42.0 Nm	84.0 Nm
Gearbox efficiency, approx.	0.80	0.75	0.70
Max. backlash	0.60 °DEG*	0.65 °DEG	0.70 °DEG
Recommended initial speed	3,000 U/min	3,000 U/min	3,000 U/min
Min. Operating temperature	-30 °C	-30 °C	-30 °C
Max. Operating temperature	+120 °C	+120 °C	+120 °C

* LN: 0,90 °DEG. For plastic PL wheels only! Impact of 1st stage for 2-4 stage versions is negligible.

Current reduction ratios i rounded

1-stage		2-stage		3-stage	
PM	LN	PM	LN	PM	LN
4:1 (3.71)	4:1 (3.65)	14:1 (13.73)	14:1 (13.53)	51:1 (50.89)	50:1 (50.16)
4:1 (4.29)	5:1 (4.59)	16:1 (15.88)	16:1 (15.65)	59:1 (58.86)	58:1 (58.01)
5:1 (5.18)	5:1 (5.36)	18:1 (18.37)	17:1 (17.00)	68:1 (68.07)	67:1 (67.08)
7:1 (6.75)	7:1 (6.55)	19:1 (19.20)	19:1 (18.92)	71:1 (71.16)	70:1 (70.13)
	9:1 (8.63)	22:1 (22.21)	23:1 (22.96)	79:1 (78.72)	81:1 (81.11)
	*13:1 (13.20)	25:1 (25.01)	25:1 (24.65)	93:1 (92.70)	91:1 (91.36)
		27:1 (26.85)	28:1 (27.76)	95:1 (95.18)	98:1 (98.07)
		29:1 (28.93)	28:1 (28.05)	100:1 (99.51)	102:1 (101.89)
		35:1 (34.98)	34:1 (33.92)	107:1 (107.21)	106:1 (105.65)
		46:1 (45.56)	45:1 (44.69)	115:1 (115.08)	115:1 (114.77)
			58:1 (58.22)	124:1 (123.98)	123:1 (123.20)
			*68:1 (64.40)	130:1 (129.62)	128:1 (127.74)
			*89:1 (89.10)	139:1 (139.14)	137:1 (136.99)
				150:1 (149.90)	145:1 (145.36)
				169:1 (168.85)	166:1 (166.40)
				181:1 (181.25)	176:1 (175.75)
				195:1 (195.27)	192:1 (191.54)
				236:1 (236.10)	232:1 (231.59)
				308:1 (307.55)	302:1 (301.68)
					393:1 (392.98)
					*462:1 (461.70)
					*601:1 (601.43)

* not all reduction ratios available ex-stock

Output side with ball bearing (2RS)	1-stage	2-stage	3-stage
Max. load, radial (Middle output shaft)	320 N	480 N	760 N
Max. load, axial	70 N	100 N	160 N
Max. perm.fitting pressure	1,300 N	1,300 N	1,300 N
Weight approx. with motor flange C80	1.4 kg	1.9 kg	2.4 kg

Gearbox length in mm	1-stage	2-stage	3-stage
Length l*	66.3 ± 0.5	85.9 ± 0.5	105.5 ± 0.5

*The minimum length is only possible with an optimal attachment to the motor, the actual length we like to determine for you.

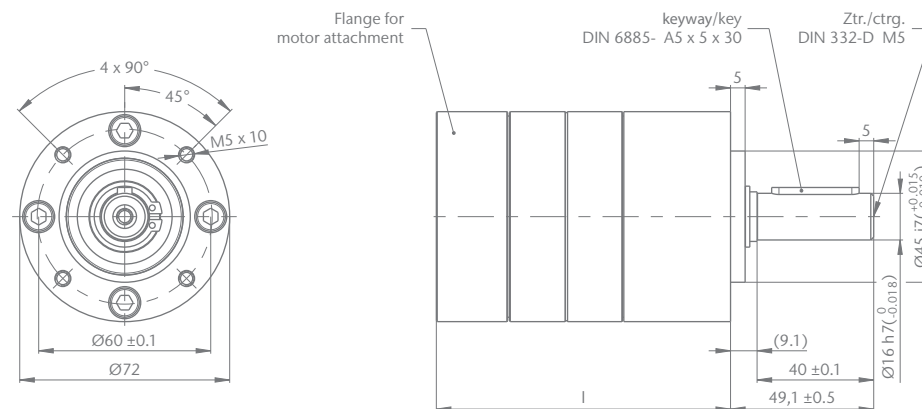

All figures are approximate values.

Variations are possible and may arise for example due to non-standardized inspection and measurement methods. For more detailed information, please contact us directly. The company always reserves the right to make technical modifications. For current status, please consult www.imsgear.com

PM 81/LN $\varnothing 81$ mm, Metall-Low-Noise

Parameter	1-stage	2-stage	3-stage
Perm. output torque Appl. factor ($C_B = 1.0$)	20.0 Nm	60.0 Nm	120.0 Nm
Gearbox efficiency, approx.	0.80	0.75	0.70
Max. backlash	0.50 °DEG*	0.55 °DEG	0.60 °DEG
Recommended initial speed	3,000 U/min	3,000 U/min	3,000 U/min
Min. Operating temperature	-30 °C	-30 °C	-30 °C
Max. Operating temperature	+120 °C	+120 °C	+120 °C

* LN: 0,85 °DEG. For plastic PL wheels only! Impact of 1st stage for 2-4 stage versions is negligible.

Current reduction ratios i rounded

1-stage		2-stage		3-stage	
PM	LN	PM	LN	PM	LN
4:1 (3.71)	4:1 (3.65)	14:1 (13.73)	14:1 (13.53)	51:1 (50.89)	50:1 (50.16)
4:1 (4.29)	5:1 (4.59)	16:1 (15.88)	16:1 (15.65)	59:1 (58.86)	58:1 (58.01)
5:1 (5.18)	5:1 (5.36)	18:1 (18.37)	17:1 (17.00)	68:1 (68.07)	67:1 (67.08)
7:1 (6.75)	7:1 (6.55)	19:1 (19.20)	19:1 (18.92)	71:1 (71.16)	70:1 (70.13)
	9:1 (8.63)	22:1 (22.21)	23:1 (22.96)	79:1 (78.72)	81:1 (81.11)
	*13:1 (13.20)	25:1 (25.01)	25:1 (24.65)	93:1 (92.70)	91:1 (91.36)
		27:1 (26.85)	28:1 (27.76)	95:1 (95.18)	98:1 (98.07)
		29:1 (28.93)	28:1 (28.05)	100:1 (99.51)	102:1 (101.89)
		35:1 (34.98)	34:1 (33.92)	107:1 (107.21)	106:1 (105.65)
		46:1 (45.56)	45:1 (44.69)	115:1 (115.08)	115:1 (114.77)
			58:1 (58.22)	124:1 (123.98)	123:1 (123.20)
			*68:1 (64.40)	130:1 (129.62)	128:1 (127.74)
			*89:1 (89.10)	139:1 (139.14)	137:1 (136.99)
				150:1 (149.90)	145:1 (145.36)
				169:1 (168.85)	166:1 (166.40)
				181:1 (181.25)	176:1 (175.75)
				195:1 (195.27)	192:1 (191.54)
				236:1 (236.10)	232:1 (231.59)
				308:1 (307.55)	302:1 (301.68)
					393:1 (392.98)
					*462:1 (461.70)
					*601:1 (601.43)

* not all reduction ratios available ex-stock

Output side with ball bearing (2RS)	1-stage	2-stage	3-stage
Max. load, radial (Middle output shaft)	400 N	600 N	1.000 N
Max. load, axial	80 N	120 N	200 N
Max. perm.fitting pressure	1,500 N	1,500 N	1,500 N
Weight approx. with motor flange C80	1.8 kg	2.5 kg	3.2 kg

Gearbox length in mm	1-stage	2-stage	3-stage
Length l*	72.8 ± 0.6	94.45 ± 0.6	116.1 ± 0.6

*The minimum length is only possible with an optimal attachment to the motor, the actual length we like to determine for you.

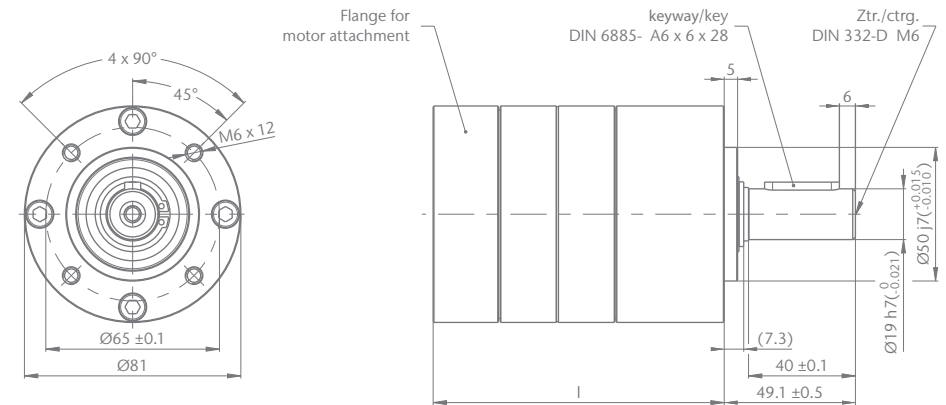

All figures are approximate values.
 Variations are possible and may arise for example due to non-standardized inspection and measurement methods. For more detailed information, please contact us directly. The company always reserves the right to make technical modifications. For current status, please consult www.imsgear.com

PM 105/LN \varnothing 105 mm, Metall-Low-Noise

Parameter	1-stage	2-stage	3-stage
Perm. output torque Appl. factor ($C_B = 1.0$)	35.0 Nm	105.0 Nm	195.0 Nm
Gearbox efficiency, approx.	0.80	0.75	0.70
Max. backlash	0.55 °DEG*	0.60 °DEG	0.65 °DEG
Recommended initial speed	3,000 U/min	3,000 U/min	3,000 U/min
Min. Operating temperature	-30 °C	-30 °C	-30 °C
Max. Operating temperature	+120 °C	+120 °C	+120 °C

* LN: 0,90 °DEG. For plastic PL wheels only! Impact of 1st stage for 2-4 stage versions is negligible.

Current reduction ratios i rounded

1-stage		2-stage		3-stage	
PM	LN	PM	LN	PM	LN
4:1 (3.71)	4:1 (3.65)	14:1 (13.73)	14:1 (13.53)	51:1 (50.89)	50:1 (50.16)
4:1 (4.29)	5:1 (4.59)	16:1 (15.88)	16:1 (15.65)	59:1 (58.86)	58:1 (58.01)
5:1 (5.18)	5:1 (5.36)	18:1 (18.37)	17:1 (17.00)	68:1 (68.07)	67:1 (67.08)
7:1 (6.75)	7:1 (6.55)	19:1 (19.20)	19:1 (18.92)	71:1 (71.16)	70:1 (70.13)
	9:1 (8.63)	22:1 (22.21)	23:1 (22.96)	79:1 (78.72)	81:1 (81.11)
	*13:1 (13.20)	25:1 (25.01)	25:1 (24.65)	93:1 (92.70)	91:1 (91.36)
		27:1 (26.85)	28:1 (27.76)	95:1 (95.18)	98:1 (98.07)
		29:1 (28.93)	28:1 (28.05)	100:1 (99.51)	102:1 (101.89)
		35:1 (34.98)	34:1 (33.92)	107:1 (107.21)	106:1 (105.65)
		46:1 (45.56)	45:1 (44.69)	115:1 (115.08)	115:1 (114.77)
			58:1 (58.22)	124:1 (123.98)	123:1 (123.20)
			*68:1 (64.40)	130:1 (129.62)	128:1 (127.74)
			*89:1 (89.10)	139:1 (139.14)	137:1 (136.99)
				150:1 (149.90)	145:1 (145.36)
				169:1 (168.85)	166:1 (166.40)
				181:1 (181.25)	176:1 (175.75)
				195:1 (195.27)	192:1 (191.54)
				236:1 (236.10)	232:1 (231.59)
				308:1 (307.55)	302:1 (301.68)
					393:1 (392.98)
					*462:1 (461.70)
					*601:1 (601.43)

* not all reduction ratios available ex-stock

Output side with ball bearing (2RS)	1-stufig	2-stufig	3-stufig
Max. load, radial (Middle output shaft)	600 N	900 N	1,500 N
Max. load, axial	120 N	180 N	300 N
Max. perm.fitting pressure	2,000 N	2,000 N	2,000 N
Weight approx. with motor flange C80	4.4 kg	6.0 kg	7.6 kg

Gearbox length in mm	1-stage	2-stage	3-stage
Length l*	94.3 ± 0.6	125.6 ± 0.6	156.6 ± 0.6

*The minimum length is only possible with an optimal attachment to the motor, the actual length we like to determine for you.

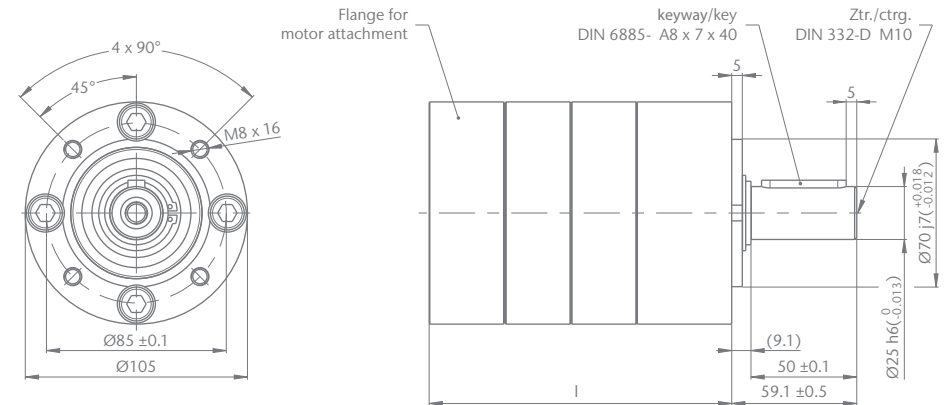

All figures are approximate values.
 Variations are possible and may arise for example due to non-standardized inspection and measurement methods. For more detailed information, please contact us directly. The company always reserves the right to make technical modifications. For current status, please consult www.ims-gear.com

PM 120 \varnothing 120 mm, Metal

Parameter	1-stage	2-stage	3-stage
Perm. output torque Appl. factor ($C_B = 1.0$)	50.0 Nm	150.0 Nm	300.0 Nm
Gearbox efficiency, approx.	0.80	0.75	0.70
Max. backlash	1.00 °DEG	1.50 °DEG	2.00 °DEG
Recommended initial speed	3,000 U/min	3,000 U/min	3,000 U/min
Min. Operating temperature	-30 °C	-30 °C	-30 °C
Max. Operating temperature	+120 °C	+120 °C	+120 °C

Current reduction ratios i rounded (PM/LN)

1-stage	2-stage	3-stage
4:1 (3.71)	14:1 (13.73)	51:1 (50.89)
4:1 (4.29)	16:1 (15.88)	59:1 (58.86)
5:1 (5.18)	18:1 (18.37)	68:1 (68.07)
7:1 (6.75)	19:1 (19.20)	71:1 (71.16)
	22:1 (22.21)	79:1 (78.72)
	25:1 (25.01)	93:1 (92.70)
	27:1 (26.85)	95:1 (95.18)
	29:1 (28.93)	100:1 (99.51)
	35:1 (34.98)	107:1 (107.21)
	46:1 (45.56)	115:1 (115.08)
		124:1 (123.98)
		130:1 (129.62)
		139:1 (139.14)
		150:1 (149.90)
		169:1 (168.85)
		181:1 (181.25)
		195:1 (195.27)
		236:1 (236.10)
		308:1 (307.55)

Output side with ball bearing (2RS)	1-stage	2-stage	3-stage
Max. load, radial (Middle output shaft)	600 N	900 N	1,500 N
Max. load, axial	120 N	180 N	300 N
Max. perm.fitting pressure	2,500 N	2,500 N	2,500 N
Weight approx. with motor flange C105	5.6 kg	8.0 kg	10.4 kg

Gearbox length in mm	1-stage	2-stage	3-stage
Length l*	109.2 ± 0.6	143.4 ± 0.6	177.5 ± 0.6

* The minimum length is only possible with an optimal attachment to the motor, the actual length we like to determine for you.

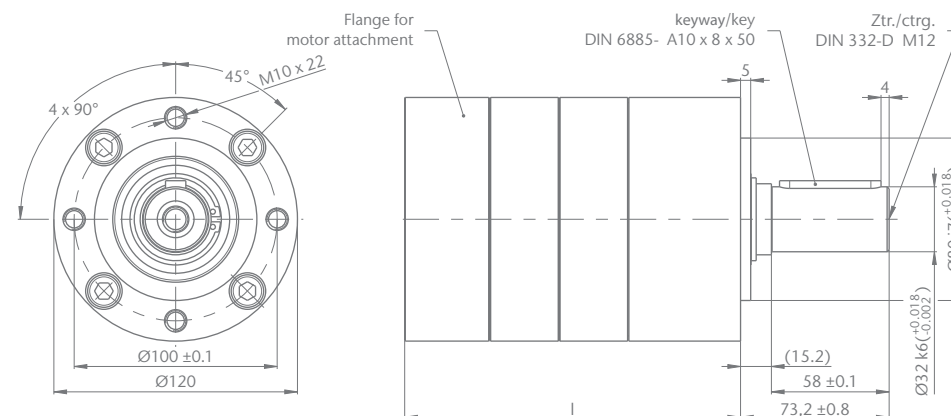

All figures are approximate values.

Variations are possible and may arise for example due to non-standardized inspection and measurement methods. For more detailed information, please contact us directly. The company always reserves the right to make technical modifications. For current status, please consult www.imsgear.com

Examples of configuration

PM 42 LN



Technical features

- 3-stage
- 393:1
- 15 Nm*

PK 52



Technical features

- 2-stage
- 25:1
- 5 Nm*

PM 22



Technical features

- 3-stage
- 51:1
- 0.8 Nm*

PM 105

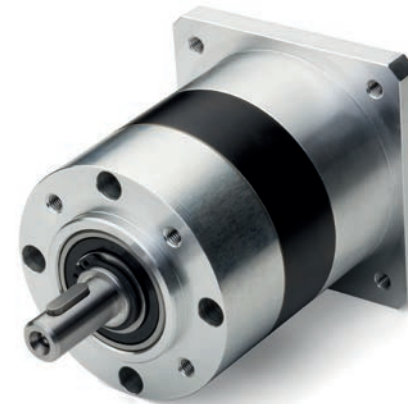

Technical features

- 1-stage
- 7:1
- 35 Nm*

*Limited output torque (operating factor $C_g=1,0$)

Optimized drive solutions from
the modular design range for planetary gears

Planetary Gears plg.technology

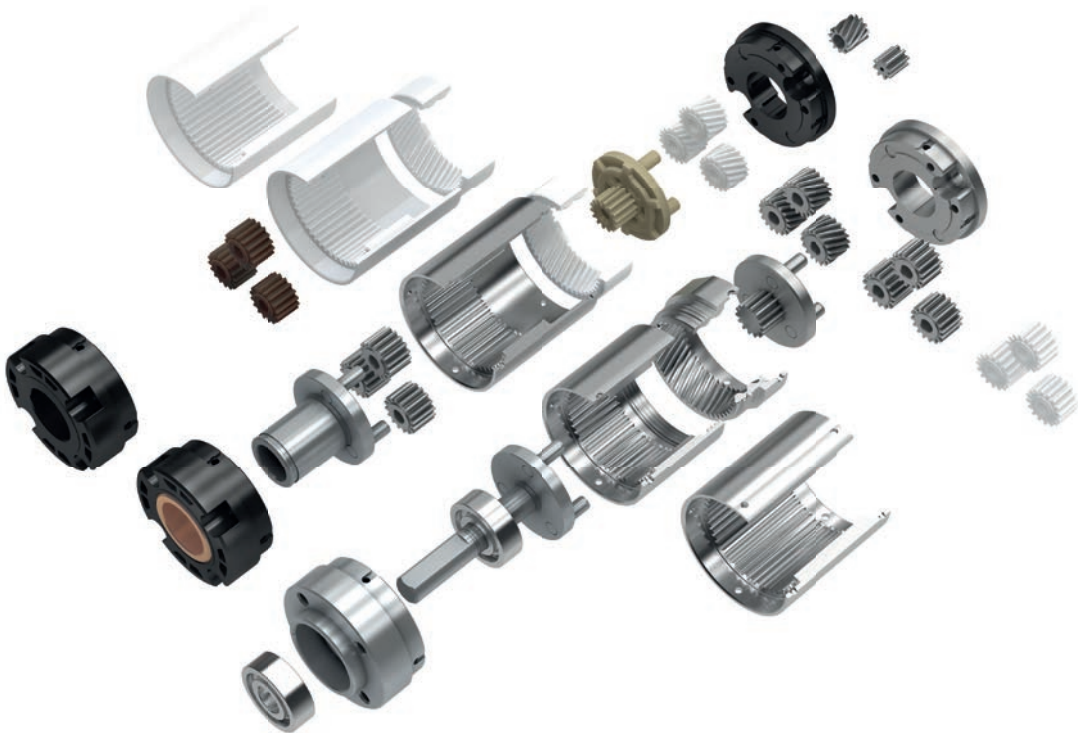

Gear Technology. Worldwide.

IMS:GEAR

Modular solutions

PLANETARY GEARS ARE RENOWNED FOR THEIR HIGH EFFICIENCY RATING. Compared to other designs of gear heads, their compact design offers a high power-to-weight ratio and a high torque transmission rating and requires minimal installation space. These factors make planetary gears the preferred fit in the design of energy-efficient drive solutions.

With its modular design concept for planetary gears, IMS Gear combines the benefits of standardization - fast availability of tried-and-tested technology and an attractive price-performance ratio even in a volume production context - with outstanding scope for individual customization.

Even the entry-level system, IMS.baseline, offers more than 1,300 possible variants in terms of motor and output end connection options. Prompt delivery assures rapid access to small to medium-sized quantities. For high-volume production applications, IMS.techline is preferred, since it offers well over 10,000 configuration options. As well

as adaptations for the motor and output end, examples being motor pinions, flanges or output components, IMS.techline can offer a broad range of reduction ratios, diameter variants and material combinations involving the use of metal and plastic. These features increase again the individualization to a certain extent by still favourable "time to market" possibilities.

IMS.SDline constitutes the ultimate option in terms of module-based individualization and optimization. It makes it possible to offer design changes to gear components while at the same time retaining the same tooth profile, explaining why it constitutes the optimum solution for entire fields of application.

This applies to all three product lines: Planetary gear solutions based on a modular design concept have much shorter lead times than bespoke or 'special' gear heads, meaning that they can get to market much faster.

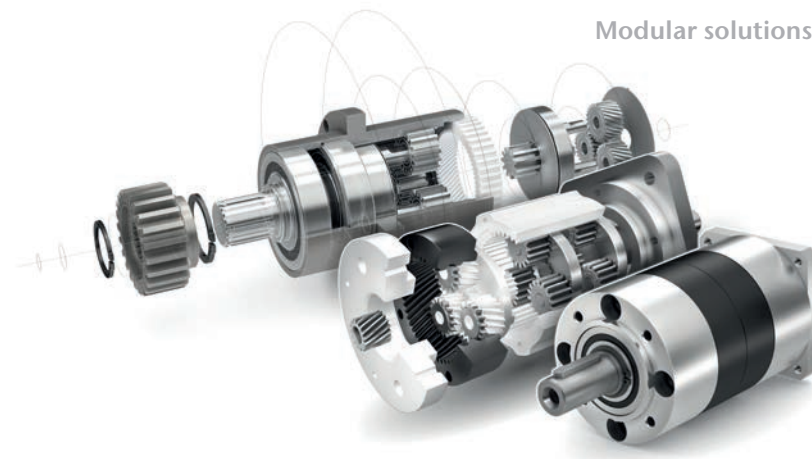

WITH ITS MORE THAN 40 YEARS OF EXPERIENCE AND EXPERTISE, IMS Gear is able to provide the market with a continuous stream of innovations relating to planetary gears, including:

- The tandem gear
- Planetary gear bearing designed to optimize service life
- Laser-welded plastic gear housings
- Various sizes combined in a single gear drive configuration
- Solid plastic planet carrier
- Plastic motor pinion
- ...

Despite having well over 10,000 configuration variants, at some point even the modular design system encounters its limits. For example with design requirements for hollow shaft gear, whole-number reduction ratios or oil lubrication, and with wishes from Production for sintered gears or grinded gear profiles.

Mind you, are you quite certain that you need these features? Talk to us: We are sure to inspire you by proposing a possible solution that you were not expecting to hear. In the majority of applications, our modular design system for planetary gears can provide viable approaches and reliable solutions.

Our know-how for your project

TO ENABLE US TO OFFER YOU OPTIMUM QUALITY, fast availability and the very latest of cutting edge technology, we are committed to having a vertically integrated scope of in-house operations - extending from development through to logistics. That lays the global foundations for optimized process right across the value-added chain and beyond, and assures maximum flexibility.

Thanks to our central Development Center in Donaueschingen we are able to make our know-how and expertise to all of our production locations right around the world.

 SOFTWARE DEVELOPMENT	 MOLD MAKING
 DESIGN	 VOLUME PRODUCTION OF PLASTIC
 MILLING	 VOLUME PRODUCTION OF METAL
 SAMPLE AND SMALL SERIES PRODUCTION	 HEAT TREATMENT TECHNOLOGY
 TEST LAB	 ASSEMBLY
 PROCESS PLANNING	 LOGISTICS

Our skills set

Your benefits

Material mix <ul style="list-style-type: none"> • Solid metal • Solid plastic • Metal-plastic mix 	<ul style="list-style-type: none"> + Noise optimization + Optimum price-performance ratio + Weight optimization
Motor connection <ul style="list-style-type: none"> • Flange-mounting to all motors worldwide • Design rating by IMS Gear 	<ul style="list-style-type: none"> + Optimum interface configuration + Free choice of motor
Quality philosophy <ul style="list-style-type: none"> • Production facilities devised to suit market needs around the globe • Standardized quality level 	<ul style="list-style-type: none"> + Production lines based on standardization + Suitable for duplication globally
Information management <ul style="list-style-type: none"> • All locations networked • Standardized systems 	<ul style="list-style-type: none"> + Standardized global information flow + Information available everywhere and at all times
Internationalism <ul style="list-style-type: none"> • Sales and production in: <ul style="list-style-type: none"> ▸ Europe ▸ NAFTA ▸ Asia 	<ul style="list-style-type: none"> + Closeness to customers + On-site service + Low exposure to exchange rate risk + Low transportation costs + High level of deadline flexibility
Volume scenario <ul style="list-style-type: none"> • Small and medium volumes with IMS.baseline • High-volume production runs with IMS.techline • Specifically optimized solutions for Interbranch applications with IMS.SDline 	<ul style="list-style-type: none"> + Optimum gear drive solutions for any volume scenario
Specialization <ul style="list-style-type: none"> • Specializing in planetary gears • No integrated system provider • Exclusive focus on planetary gear development 	<ul style="list-style-type: none"> + Independence from motor manufacturers + Insider in the planetary gear technology sector + New developments can be adapted rapidly + Consistent further development of the modular system concept

TOTAL OF PROPERTIES OF
IMS GEAR PLANETARY GEARS

MORE THAN 150 YEARS OF TRANSMISSION EXPERIENCE, OF WHICH 40 YEARS INVOLVED WITH PLANETARY GEARS

Internationalism

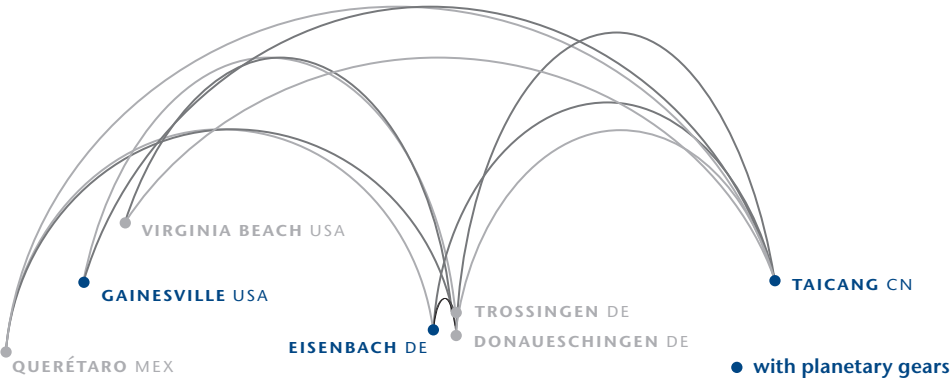

Fields of application

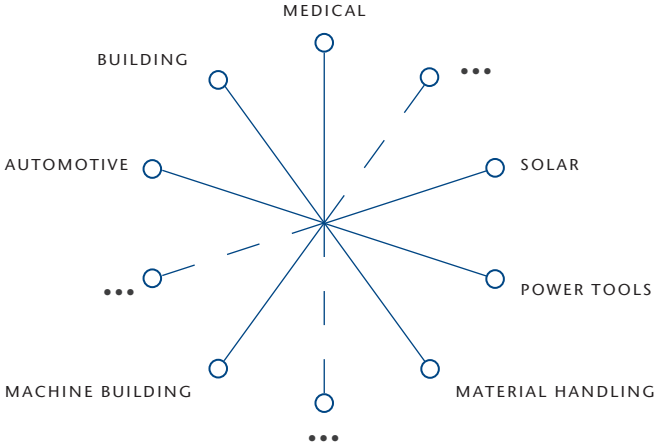

Gear head diameter

in mm

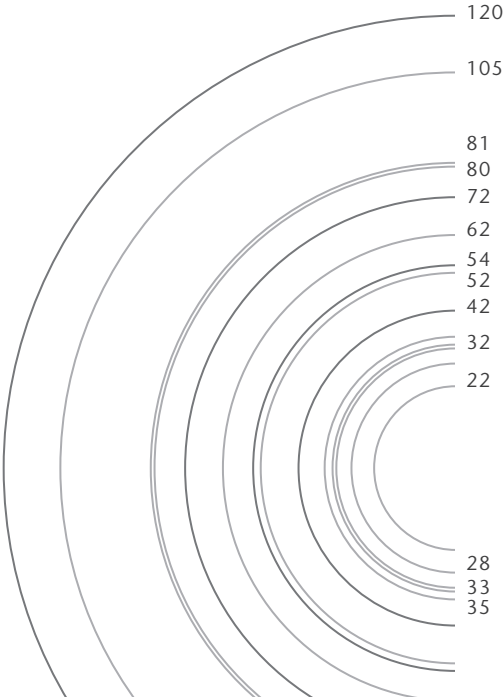

Material

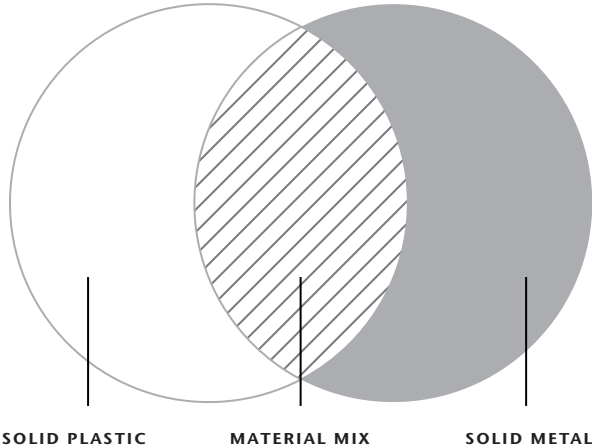

Like the Solar System

OPERATING METHOD: Planetary gears function as their name implies: At their center is a 'sun gear' driven by the motor. This transmits its rotational movement to three satellite-like 'planet gears' that comprise one gear stage. They are arranged on the bearing bolts of a planetary carrier.

The last planet carrier is rigidly mounted to the output shaft, enabling it to transmit power to the output end. The outside circumference of the planet gears rotate inside an internally splined transmission housing, known as the ring gear or 'annulus'.

PROPERTIES: The input and output are arranged coaxially, and the shafts rotate synchronously. Planetary gears are suitable for clockwise as well as counter-clockwise rotation, for alternating, continuous as well as intermittent operation, and are characterized by their high efficiency rating.

Compared to other designs of transmission, their compact design delivers a great power-to-weight ratio - in other words high torque transmission levels from a remarkably small installation space.

What you really need to know about our gear drives

DRIVING TORQUE

Output torque is the most important parameter when choosing a planetary gear head. Gear reduction reduces the relatively high rotational speed of the motor (rpm), delivering a lower rotational speed at the output end. This increases the output torque in an inverse ratio.

CONNECTING FLANGE

This is where the flexibility of the PLG manufacturer comes into its own. All IMS Gear planetary gear heads can be adapted to fit all (!) motors. Individual solutions are possible at the input and output ends.

LOAD ON OUTPUT

As different manufacturers use different measuring methods, great care must be taken when seeking to make a comparison. We would be pleased to calculate the maximum axial and radial load for your specific application under consideration of all parameters. Higher loads can be achieved through design measures.

OPERATIONAL DYNAMICS

High levels of operational dynamics, achieved through low inertia torques, smooth running and low levels of mechanical wear. IMS Gear Planetary Gears uses plastic instead of metal for its planetary gears wherever appropriate and technically feasible. This delivers low inertia torques. Smooth running is something we achieve when required through the use of high-quality needle bearings, or through the low friction coefficients achievable between plastic and metal. We achieve low levels of mechanical wear through our specialist design of gearing and through the use of plastic gears. The material mix characteristics of IMS Gear assures superlative operational dynamics. *Also refer to ball bearings*

OPERATING FACTOR c_B

The mentioned operating factor $c_B = 1,0$ does refer to a constant direction of rotation, no shock load and a daily operating time of 3 hours.

OPERATING TEMPERATURE

The operating temperature depends on the material and lubrication. Our pure metal versions with standard lubrication range between -30° and $+120^{\circ}$ C, the PK-series made of plastic between -15° und $+65^{\circ}$ C.

SEALING MEASURES

The types of protection are defined in acc. with DIN EN 60529. IMS.baseline gear drives fulfill the following protection categories:

- Gear drives with sintered bearings: IP40
- Gear drives with ball bearings (2RS): IP53

Upon request you can obtain output and motor gaskets that enable you to leverage higher protection classes.

INSTALLATION POSITION

Due to grease lubrication the planetary gear drives of IMS Gear can be installed in any desired position. In vertically arranged outputs, additional sealing measures can be provided upon request.

GEAR BACKLASH

Gear backlash depends on a large number of factors: Type of load, number of gear ratios, bearing, version or combination of materials. When seeking to compare different manufacturers, always remember that here, too, there are no standardized measuring methods.

BALL BEARINGS

In standard versions, the outer race of the ball bearing is designed as a rigid interference fit, while the inner race on the output shaft is designed as a loose interference fit (i.e. one capable of rotation). If required, other designs can also be provided.

SERVICE LIFE

Depending on environmental conditions and the operating data of the drive system, the service life of a PLG ranges between 200 and 15,000 hours. The great variety of application options precludes any generally applicable forecast of service life.

SCOPE OF DELIVERY

IMS Gear Planetary Gears can supply you with gears completely assembled and tested with any motor of your choice, or singly with a motor pinion for self-assembly.

LUBRICATION

Our PLG's are lubricated with grease and therefore maintenance-free during their service life. Depending on requirements profile, we select the optimum lubricant from more than ten options.

LOW-NOISE TRANSMISSIONS

To obtain optimum acoustic performance, increased demands on concentricity and axial run-out of the motor end plate, flange and shaft need to be met. Axial forces act on the motor shaft due to helical gearing. Sufficient dimensioning of the motor shaft bearings should be taken into account here. To counteract the grease-promoting effect of helical gears, radial shaft sealing rings or sealed motor bearings can be used.

OVERLOAD TORQUE

Maximum overload torque (impact loading) is the short-term overloading of the permitted output torque, i.e. when starting the motor. In case of plastic PLG's the peak load equals the overload. In case of metal-plastic combinations or full metal versions the overload torque can even amount to 1.5 times the peak load.

GEAR REDUCTIONS

By changing the number of teeth of the sun wheel and the planetary wheels, a number of reductions are possible in one stage. IMS Gear Planetary Gears combines

reduction ratios in up to four gear stages. This allows the realization of a huge variety of different gear specifications.

HEAT TREATMENT

Structural conversion during hardening of the individual metal parts acts positively on the strength and wear behavior of the gears. IMS Gear has its own heat treatment shop. As the entire metal manufacturing is inhouse, we can choose from various steels for hardening.

EFFICIENCY

The gear efficiency rating only takes account of the rolling motion of the gear, whereas the gear head efficiency rating takes account of all the losses of the entire bearing. We also always quote the transmission efficiency rating at this point. By necessity this is lower than the gear efficiency rating. As there are no standardized measuring methods, a comparison of efficiency levels of different manufacturers always requires special attention. In case of any specific requirements, please talk to us.



All figures in this brochure are approximate values. Variations are possible and may arise for example due to non-standardized inspection and measurement methods. For more detailed information, please contact us directly.

The company always reserves the right to make technical modifications.

For current status, please consult our website www.imsgear.com

Our international locations

IMS Gear GmbH

Hauptstrasse 52
79871 Eisenbach
Germany

Tel. +49 (0)771 8507-282
Fax +49 (0)771 8507-220

plg.de@imgear.com

IMS Gear Planetary Gears Inc.

1234 Palmour Drive
Gainesville, GA 30501
USA

Tel. +1 770 840-9600 ext. 159
Fax +1 770 840-8044

plg.us@imgear.com

IMS Gear (Taicang) Co. Ltd.

Building B, No. 8 Xixin Road
Fortune Land Euro-US Industrial Park
Chengxiang Town
Taicang, Jiangsu 215411
China

Tel. +86 (0)512 5367 8200
Fax +86 (0)512 5367 8399

plg.cn@imgear.com