

Design Data	
Commutation	Brushed
Direction of rotation	Bi-directional
Bearing type	A:Ball - B:Sleeve

Performance data		
Rated voltage [V]	U_N	24
Nominal torque [Nm]	M_N	2.00
No-load speed [min^{-1}]	n_0	160.0
Nominal power [W]	P_N	30.9
Nominal current [A]	I_N	4.0
Nominal force [kN]	F_N	0.00
Duty cycle	s1	

Sensor data	
Pulses	1
Output channels	2

Other data	
Gear ratio	53/2
Gear wheel material	plastic
Suppression components	6 μ H, 1nF
Enclosure class	IP 30
Weight [kg]	1.210

Remarks: d= for thread forming screw M6 DIN ISO 965-2

Characteristic curves

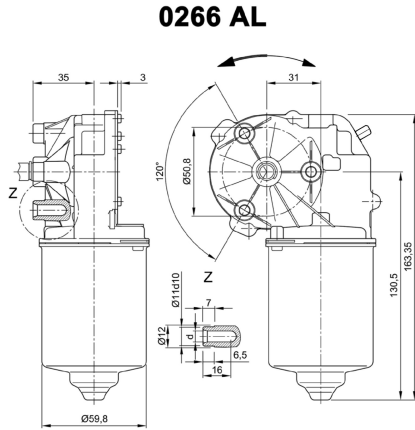

Motor picture

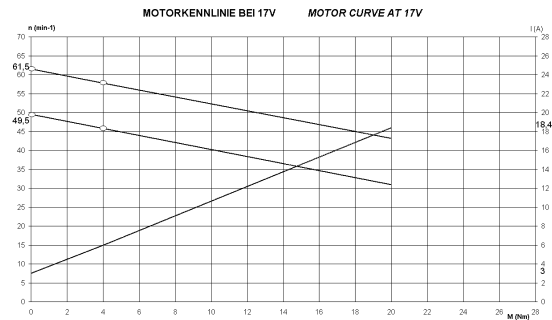

Output shaft drawing (W), Wiring diagrams (S) and Connector layout (K)

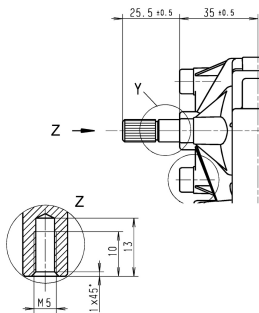

S 30

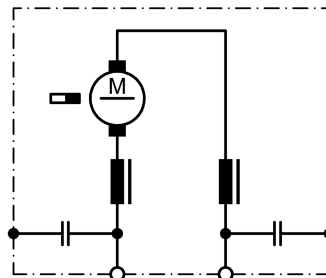

K 320

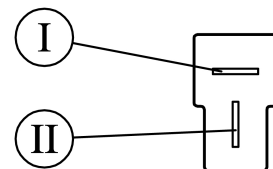

I serration (rolled): No teeth 28, pitch circle dia 9 mm, tip circle dia 9.6 mm, root circle dia 8.26 mm space width angle 60° - go/no go gauge Frenco 33906 - www.frenco.de

Flat plug (DIN 46244) 6,3x0,8 mating with receptacle housing part#180907, drwg# C-180907& Receptacles for tabs, conductor cross section 0,5-1,5 sqmm (20-18AWG) part# 925603-x, drwg# 925603 www.tycoelectronics.com